

SUDHAKAR

PROFILE SYSTEMS

BUILDING QUALITY WITH INNOVATION

— The perfect frame to your view —





SUDHAKAR
PROFILE SYSTEMS

ABOUT US —

Sudhakar Profile Systems is a product of Sudhakar Group which is a leading business conglomerate headquartered in Suryapet, Telangana with 9 manufacturing plants spread across PAN India. The group was the first to introduce PVC extrusion in South India while diversifying into a major construction, infrastructure and agricultural product supplier in India. Currently Sudhakar is in the top 5 producers of extrusion products in India.

The company started with fabrication of windows and doors in the year 2015 and later started extrusion of uPVC profiles with State of the Art plant in Andhra Pradesh.





SUDHAKAR
PROFILE SYSTEMS

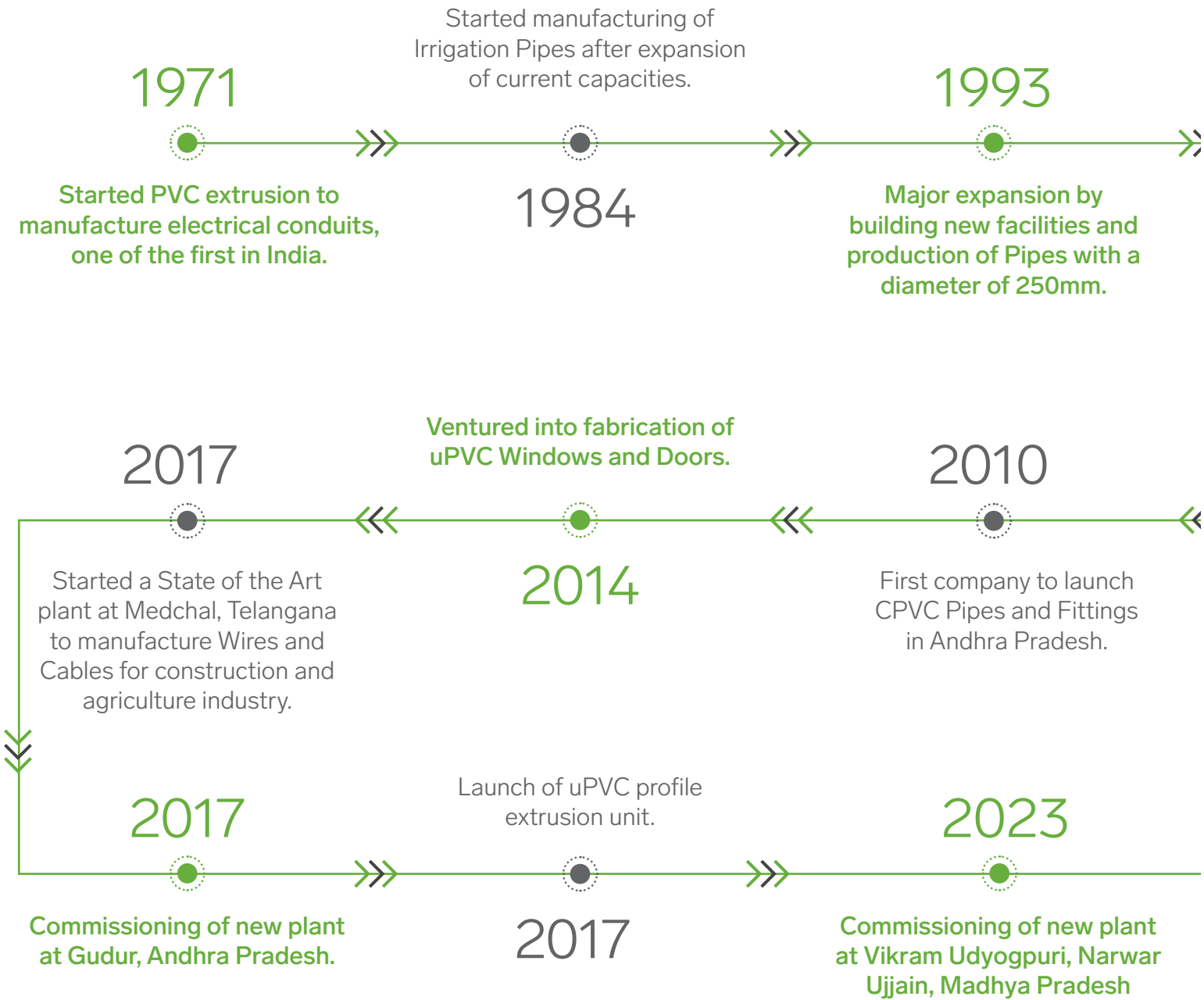

First company in South India to launch Soil, Waste and Rain (SWR) Pipe systems. Manufacturing of Irrigation Pipes up to 315mm.

1996

1997

Manufacturing of Irrigation Pressure Fittings.

Expansion into more agricultural products by launching micro Irrigation and High Density Poly Ethylene (HDPE) Pipes.

1998

Commissioning of Berhampur plant in Orissa with multiple product ranges.

2010

2004

First plant outside erstwhile Andhra Pradesh was setup in Bellary, Karnataka.

Increased in production capacity with sizes up to 400mm diameter.

2002

MILE STONES OF SUDHAKAR GROUP —

PRESENCE OF SUDHAKAR —

Innovative verticals are becoming best-in-class proposition experts. So we can hit the ground running, we will be conservatively investing every stand-up in our space. Is your alignment prepared for competitive core competency growth? You need to globally relay your game changers to increase your architecture velocity.



Sales Offices

Telangana

- Hyderabad
- Warangal
- Suryapet

Andhra Pradesh

- Vijayawada
- Visakhapatnam
- Nellore
- Kurnool

Odisha

- Bhubaneswar
- Berhampur

Chattisgarh

Uttar Pradesh

New Delhi

Bihar

Uttarakhand

Rajasthan

Karnataka

- Bellary
- Bangalore
- Hubli

Maharashtra

Tamilnadu

- Chennai
- Madhurai

Jharkhand

- Ranchi

West Bengal

- Kolkata

Madhya Pradesh

- Indore



Manufacturing units

Telangana

- Hyderabad
- Suryapet

Andhra Pradesh

- Gudur

Karnataka

- Bellary

Odisha

- Berhampur

Madhya Pradesh

- Ujjain



TROPICAL MIX —

In high UV radiation zones such as the Indian sub continent, we need extra protection against the harmful effects of sunlight.

We at Sudhakar use a special blend of material with high UV stabilizer. This makes the profiles last longer under the harsh Indian sun without any de-colouration.

ADVANTAGES OF SUDHAKAR PROFILE SYSTEMS



Water Resistant



Sound Insulation



Thermal Insulation



Energy Efficient



Wind Resistant



Eco Friendly



Termite Free



SUDHAKAR
PROFILE SYSTEMS

SLIDER SYSTEMS —

SUDHAKAR sliding uPVC Window and Door systems are designed for Harsh Indian weather conditions. Heavy duty sections give higher and wider openings than industry standard, allowing more light and air in.

Bug Mesh shutters can be given as standard option, or can be added later for protection from insects. Slider systems can be combined with casement systems for greater design flexibility.

Heavy Duty Window and Door Sash Sections from 60mm to 88mm in 2 track, 2.5 track and 3 track outer Frames with mesh and without mesh.



— SUDHAKAR'S SLIDER SYSTEM PROVIDES —

5 to 24 mm glass thickness for slider system	Bigger slopes for Indian monsoon conditions	Aluminum track for smooth operations and durability	Multiple track options - 2 track, 2.5 track, 3 track and addon track
Multiple Sash options available 60mm, 68mm, 78mm 82mm & 88mm	Bigger reinforcement provision for high wind load conditions	Profile with Euro Grove for better hardware fixing	Hurricane bar for high rise buildings
Extra web support for stability	Provision of mosquito mesh for Windows and Doors	Unique mosquito mesh inset for perfect mesh fixing	Heavy duty Low Threshold

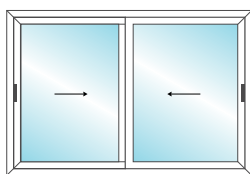

2T2P

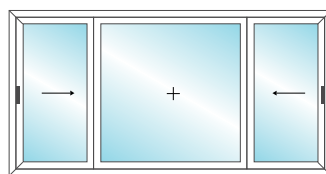

2T3P

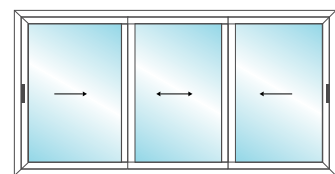

3T3P

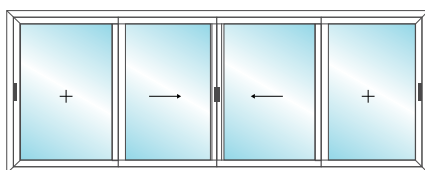

2T4P

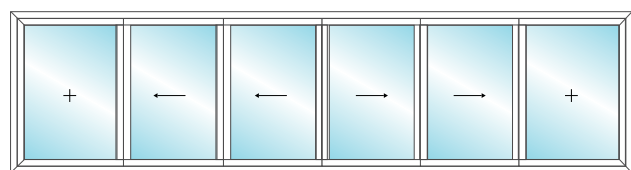

3T6P

SLIDING SYSTEMS —

PRIMA SERIES

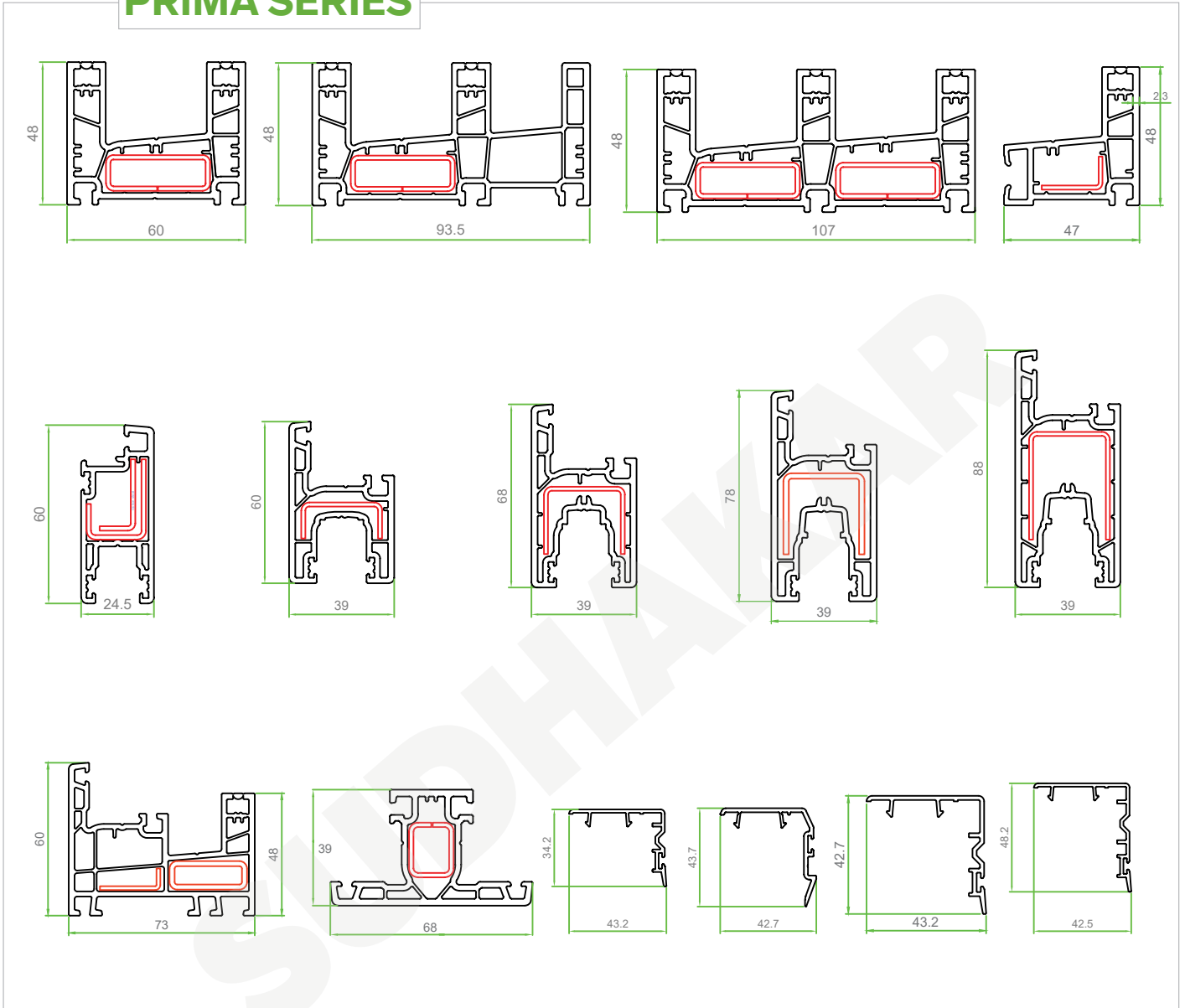

ECO SERIES

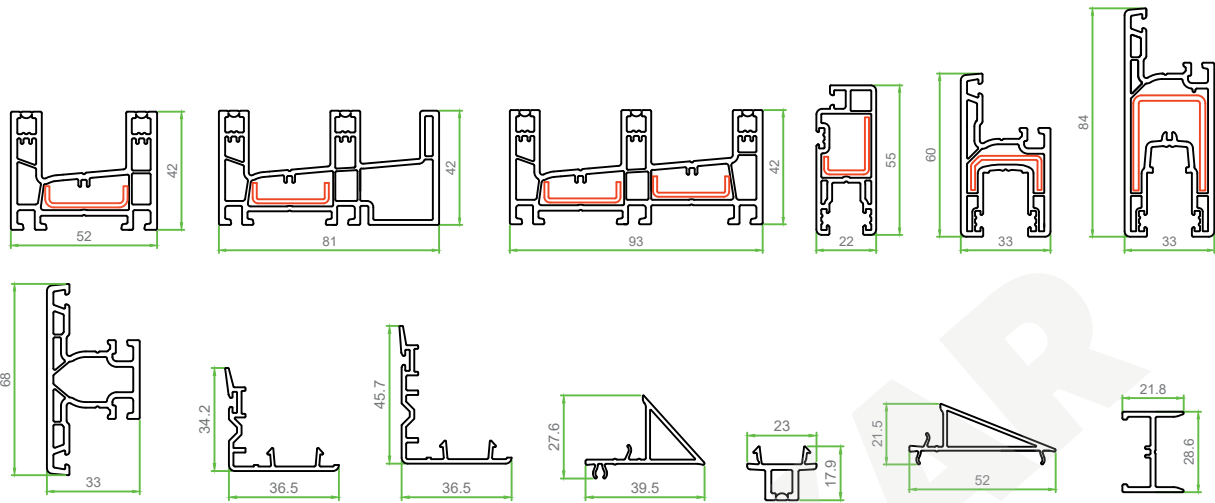

ROYAL SERIES

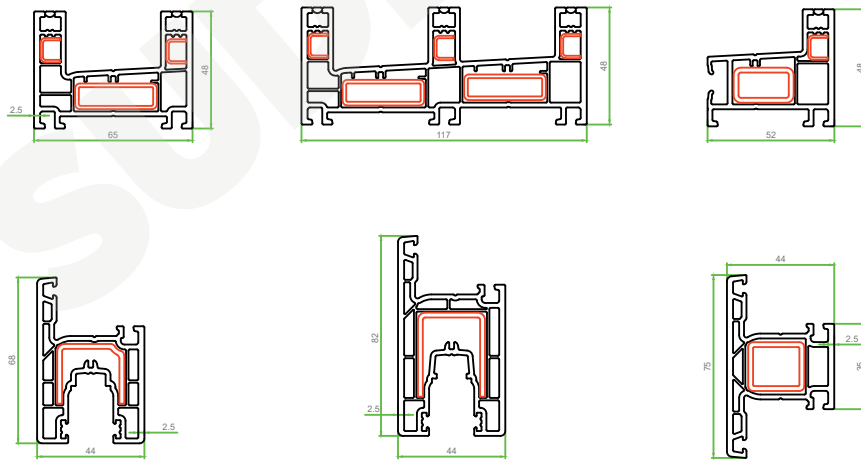

CASEMENT SYSTEMS —

Sudhakar's casement uPVC window and door systems have a 3 & 5 chamber system with 60 mm & 65mm construction depth. It is a 2 gasket system that seals and maintains temperature.

Casement system is designed with internal gaskets exchangeable giving flexibility for the customer to choose from various glass thicknesses. Outward open window can be fixed with a grill provision and inward open mesh even on 4 inch wall.

The system can be designed for heavy wind load regions without affecting the long-term performance of the window and door.



— SUDHAKAR'S CASEMENT SYSTEM PROVIDES —

High energy saving	Various types of combinations and designs	Multiple frame and sash options	5 mm - 38 mm glass thickness available
Water groove to stop inwards flow	Profile with Euro Groove for secured hardware fixing	Bigger reinforcement provision for high wind load conditions	Grill and Mosquito mesh provision on a 4 inch wall
Double weather-stripping for maximum air tightness and noise reduction	90° sash opening for easy cleaning	Sturdy multipoint locking mechanism	Extra web support for higher strength
Slope angle for very easy water flow and dirt reduction	Extra deep chamber for better vapour pressure and drainage	Flat bottom surface for easy mounting on brick concrete...	Striker plates and friction hinge mounted in steel for extra strength (burglarproof)

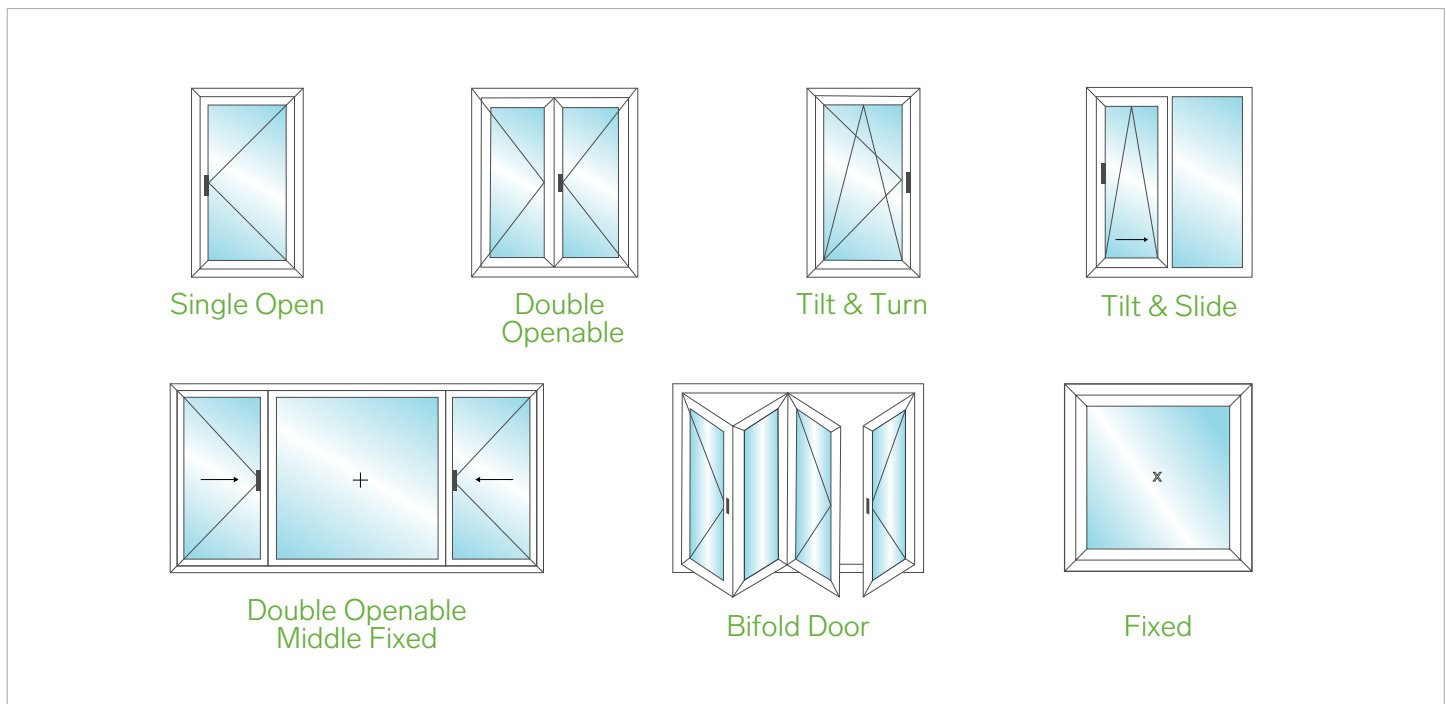

CASEMENT SYSTEMS —

PRIMA SERIES

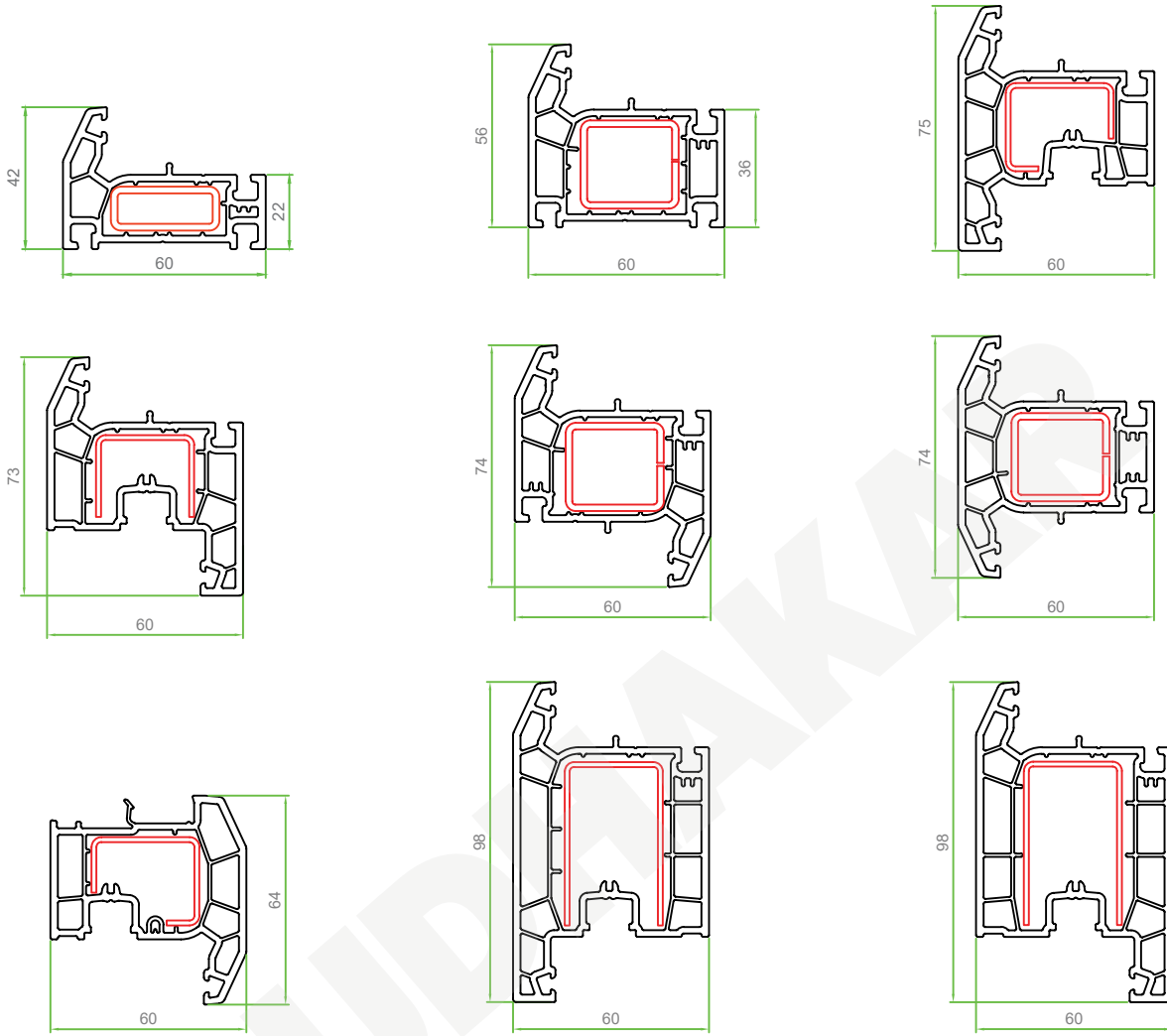

ROYAL SERIES

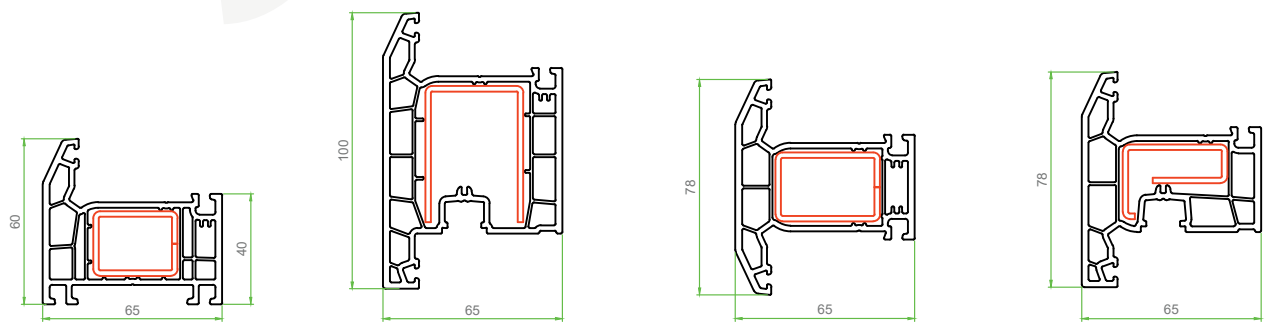

GLASS BEAD

PRIMA, ECO, ROYAL SERIES



ROYAL SERIES

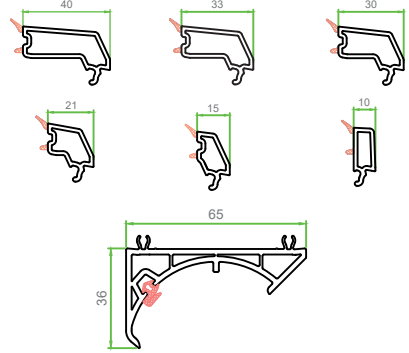

PRIMA, ROYAL SERIES

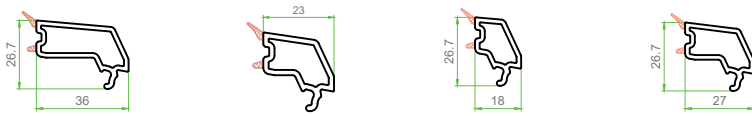

AUXILIARY SYSTEMS —

PRIMA SERIES AUXILIARY SYSTEMS

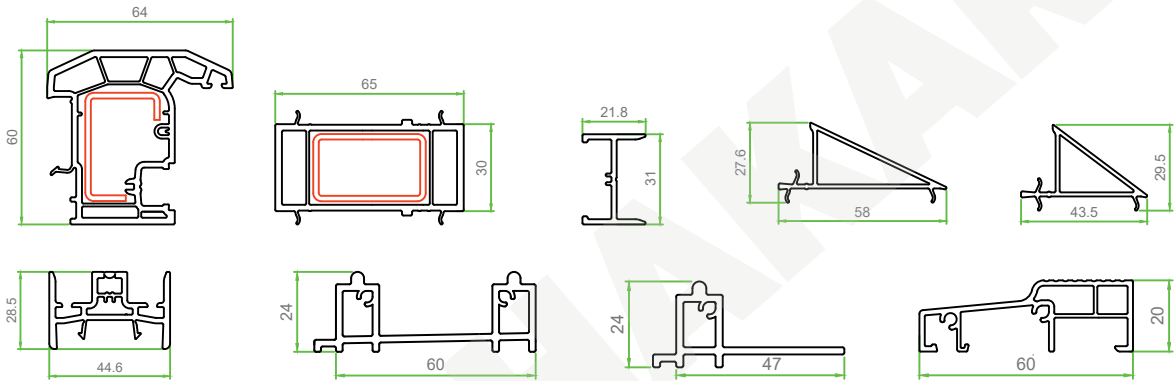

PRIMA, ECO, ROYAL SERIES

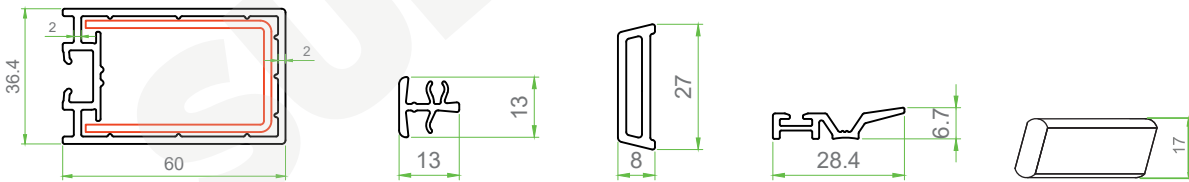

PRIMA, ROYAL SERIES

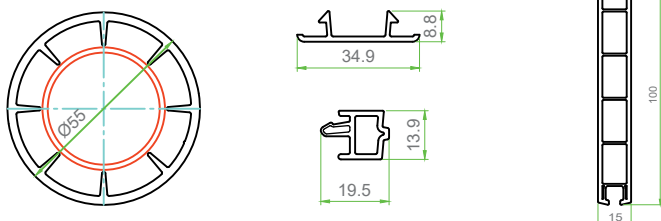

ROYAL SERIES

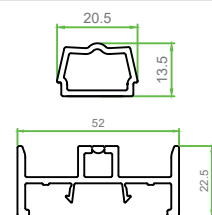

COLOR PROFILES OPTIONS

Sudhakar Profile Systems uses high quality laminate developed and produced in Germany to withstand high UV and temperatures of Indian climate. Sudhakar is offering the following laminates.

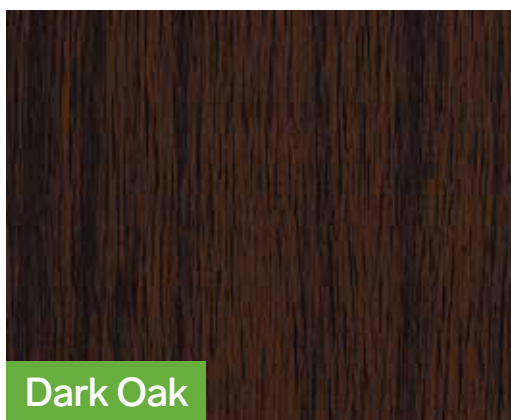
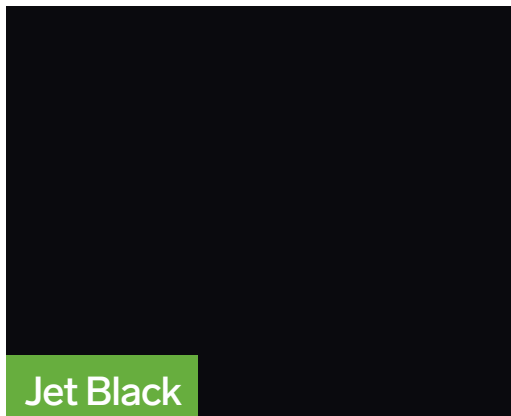

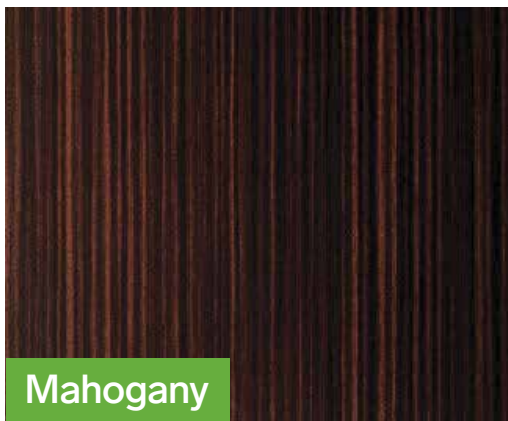

Sudhakar also supplies various combinations of laminations with single or double sided foiling.

WHY SUDHAKAR PROFILES WILL BE YOUR FIRST CHOICE EVERY TIME —



Sustainability

- Lead Free
- Easy to recycle

.....

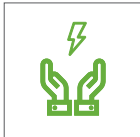

Insulation and Energy Saving

Saves energy during all seasons

.....



Minimal Maintenance

- Easy to clean using a mild detergent
- Only a few hardware items need occasional lubrication

.....

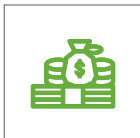

Cost Competitive

Value for money with low costs for high quality

.....



Durability

- Durable for years
- Strong, sash resistant frames to avoid outsider penetration
- Termite resistant
- Moulds, rust and corrosion free

.....



Design Capabilities

- Combination can be fabricated according to customer needs
- Available in various colours inside and outside
- European Technology

.....

CERTIFICATES

1. RoHS TEST REPORT

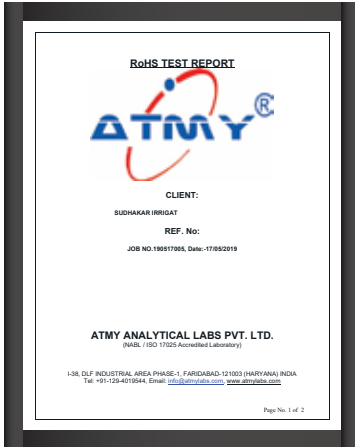

2. PHYSICAL TEST REPORT

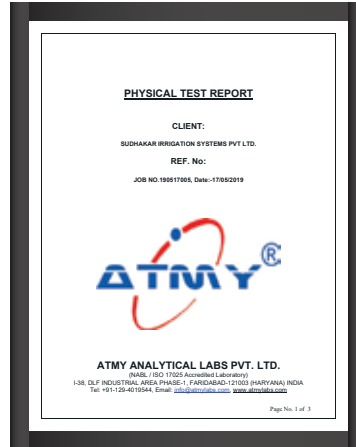

3. SUDHAKAR IRRIGATION SYSTEMS RoHS REPORT-TUV



4. CIPET TEST RESULT



5. CIPET TEST RESULT PART 2



6. SUDHAKAR_TEST REPORT NO

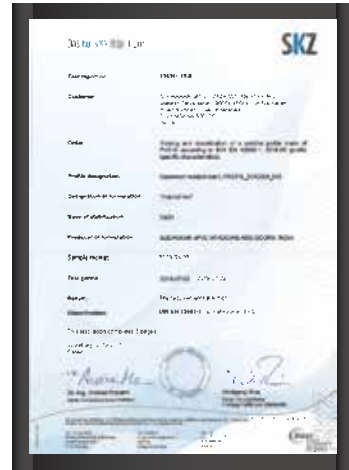

— Authorized Fabricator —



BUILDING QUALITY WITH INNOVATION

Liaison Office:

303, Ramchander House, Opp Udai Omni Hospital
Chapel Road, Hyderabad-500 001.
Phone: +91 77299 88981/ 82
Email: sales.windows@sudhakarind.com
Website: www.sudhakarind.com

Head Office:

Sudhakar PVC Products Private Limited.
Sy. No. 74/P, 75/P, 77/P & 85/P, Balaram Thanda
Near Industrial Estate, Suryapet, Telangana-508 213.

Extrusion Unit:

Survey No. 522/1, 522/2A & 1005/2, Yeguvarajupalem(V)
Tirupati Dist. A.P.-524 410.