

RUDRA METALS

CORPORATE OFFICE MUMBAI





3/4" WINDOW SECTION

3/4" Handle

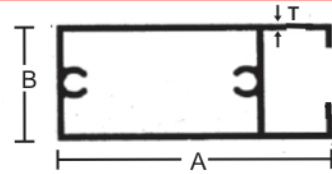

Sr. No.	Section No.	A	B	T	Wt Range Kgs/12ft
1	20011	40.00	18.00	0.60	0.800 - 0.900
2	20012	40.00	18.00	0.79	1.000-1.200
3	20013	40.00	18.00	0.92	1.200-1.400
4	20014	40.00	18.00	1.20	1.400-1.600
5	20015	40.00	18.00	1.50	1.800-1.950

3/4" Middle

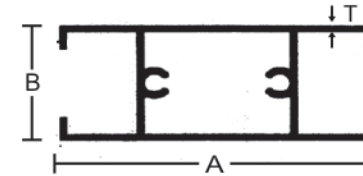

Sr. No.	Section No.	A	B	T	Wt Range Kgs/12ft
1	20025	42.00	18.00	0.60	0.800-1.000
2	20026	42.00	18.00	1.00	1.200-1.400

3/4" Inter Lock

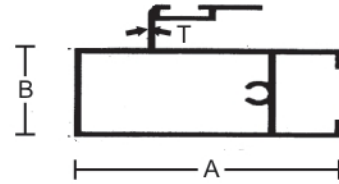

Sr. No.	Section No.	A	B	T	Wt Range Kgs/12ft
1	20016	40.00	18.00	0.79	1.200-1.400
2	20017	40.00	18.00	0.95	1.400-1.550
3	20018	40.00	18.00	1.20	1.550-1.700
4	20019	40.00	18.00	1.50	2.000-2.200

3/4" Long Bearing Bottom

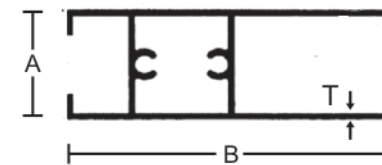

Sr. No.	Section No.	A	B	T	Wt Range Kgs/12ft
1	20027	52.10	18.00	0.85	1.200-1.400
2	20028	52.10	18.00	1.10	1.400-1.600
3	20029	52.10	18.00	1.5	2.400-2.500

3/4" Top Bottom

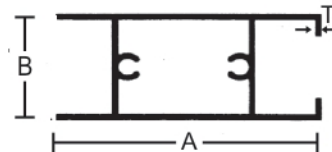

Sr. No.	Section No.	A	B	T	Wt Range Kgs/12ft
1	20020	40.00	18.00	0.73	1.000-1.200
2	20021	40.00	18.00	0.93	1.200-1.400
3	20022	40.00	18.00	1.10	1.400-1.600
4	20023	40.00	18.00	1.20	1.600-1.750
5	20024	40.00	18.00	1.35	1.800-1.950

ALL DIMENSIONS IN MM. • WEIGHT TOLERANCES ± 7 TO 10%



3/4" WINDOW SECTION

3/4" 2 Track Top

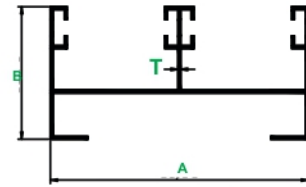

Sr. No.	Section No.	A	B	T	Wt Range Kgs/12ft
1	20030	61.85	31.75	0.84	1.600-1.800
2	20031	61.85	31.75	0.94	1.800-2.000
3	20032	61.85	31.75	1.04	2.000-2.200
4	20033	61.85	31.75	1.14	2.200-2.500
5	20034	61.85	31.75	1.20	2.600-2.700
6	20035	61.85	31.75	1.50	2.700-2.900

3/4" 3 Track Bottom

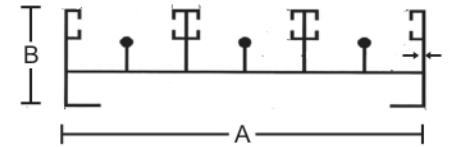

Sr. No.	Section No.	A	B	T	Wt Range Kgs/12ft
1	20044	92.00	31.50	0.80	2.600-2.800
2	20045	92.00	31.50	1.10	3.200-3.400
3	20046	92.00	31.50	1.50	4.500-4.700

3/4" 2 Tr Bottom

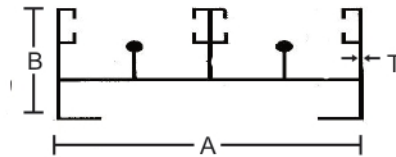

Sr. No.	Section No.	A	B	T	Wt Range Kgs/12ft
1	20036	61.85	31.75	0.85	1.700-1.900
2	20037	61.85	31.75	1.00	2.000-2.200
3	20038	61.85	31.75	1.15	2.300-2.500
4	20039	61.85	31.75	1.50	3.100-3.400

3/4" 4 Track Top

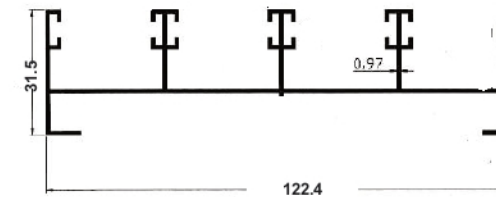

20047

WT KG/12FT=3.400

3/4" 3 Track Top

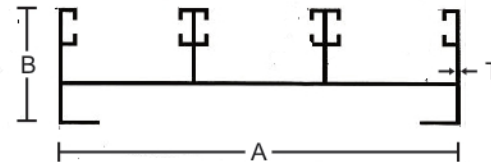

Sr. No.	Section No.	A	B	T	Wt Range Kgs/12ft
1	20040	92.00	31.50	0.85	2.200-2.400
2	20041	92.00	31.50	0.95	2.700-3.000
3	20042	92.00	31.50	1.30	3.400-3.600
4	20043	92.00	31.50	1.50	3.700-3.900

3/4" 4 Track Bottom

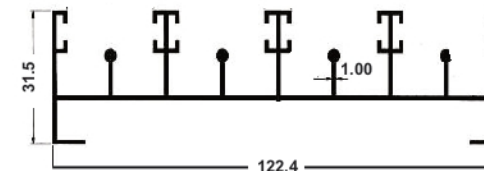

20048

WT KG/12FT=5.100



1" WINDOW SECTION

1" Handle

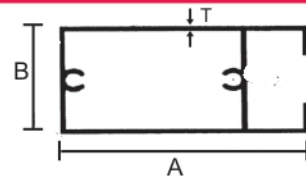

Sr. No.	Section No.	A	B	T	Wt Range Kgs/12ft
1	20049	43.00	25.00	0.80	1.250-1.300
2	20050	50.00	25.00	0.75	1.300-1.350
3	20051	50.00	25.00	0.80	1.400-1.500
4	20052	50.00	25.00	0.85	1.500-1.700
5	20053	50.00	25.00	1.20	2.100-2.300
6	20054	50.00	25.00	1.40	2.400-2.600
7	20055	50.00	25.00	1.50	2.600-2.800
8	20056	75.50	25.50	1.20	2.800-3.000

1" Middle

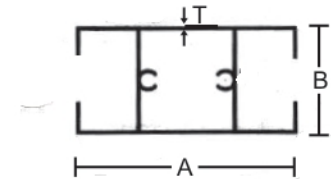

Sr. No.	Section No.	A	B	T	Wt Range Kgs/12ft
1	20060	50.00	25.00	0.70	1.450-1.550
2	20061	50.00	25.00	1.40	2.100-2.400
3	20062	75.50	25.00	1.70	2.800-3.200

1" Interlock

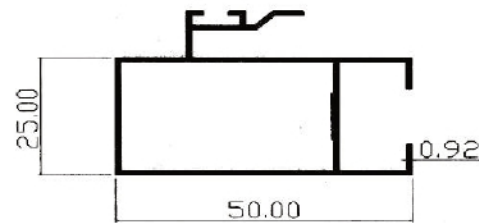

20057

WT KG/12FT=2.400

1" Top Bottom

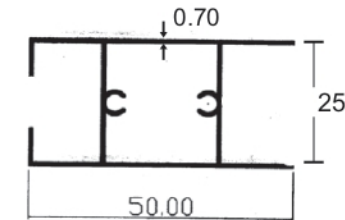

20063

WT KG/12FT=1.450

1" Bearing Bottom

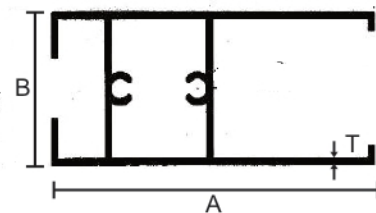

Sr. No.	Section No.	A	B	T	Wt Range Kgs/12ft
1	20058	60.00	25.00	0.70	2.500 - 2.600
2	20059	60.00	25.00	1.00	3.000 - 3.100



ALL DIMENSIONS IN MM. • WEIGHT TOLERANCES ±7 TO 10%



1" WINDOW SECTION

1" 2 Track Top

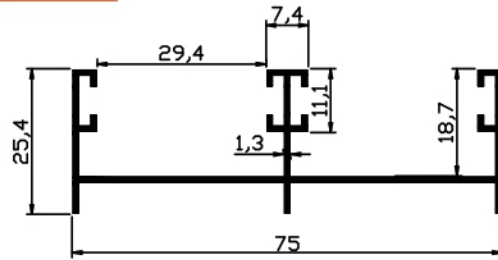

20077

WT KG/12FT=2.500

1" 3 Track Top

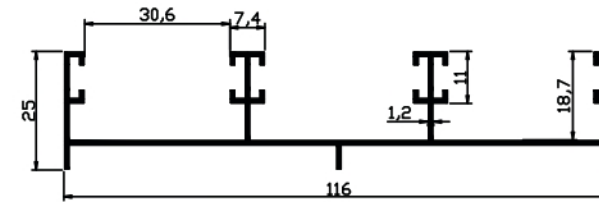

20080

WT KG/12FT=3.400

1" 2 Track Bottom

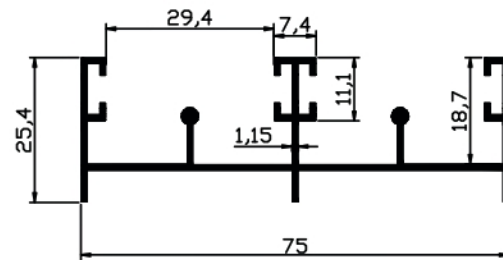

20078

WT KG/12FT=2.500

41MM 3 Tr Top

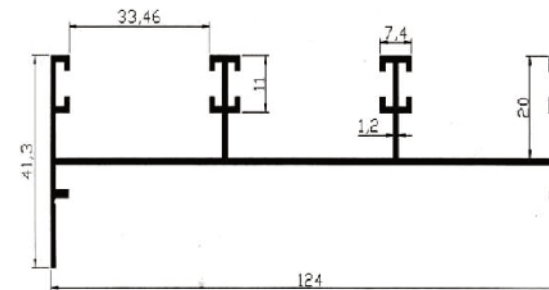

20081

WT KG/12FT=3.700

1" 3 Track Bottom

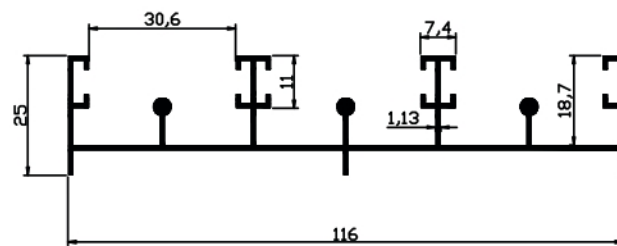

20079

WT KG/12FT=3.600

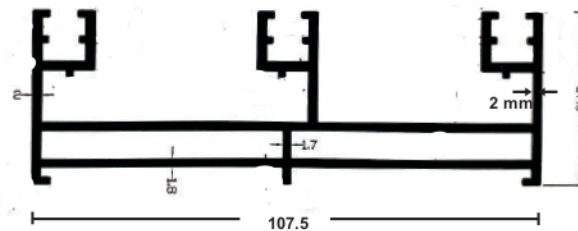

20082

WT KG/12FT=7.450

ALL DIMENSIONS IN MM. • WEIGHT TOLERANCES ± 7 TO 10%



20MM WINDOW SECTION

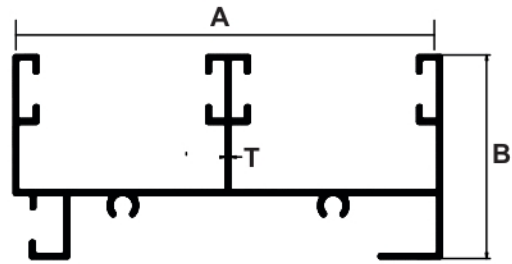

Sr. No.	Section No.	A	B	T	Wt Range Kgs/12ft
1	20086	62.00	29.50	0.75	1.500-1.600
2	20087	62.00	29.50	1.00	1.900-2.000
3	20088	62.00	29.50	1.45	3.000-3.100

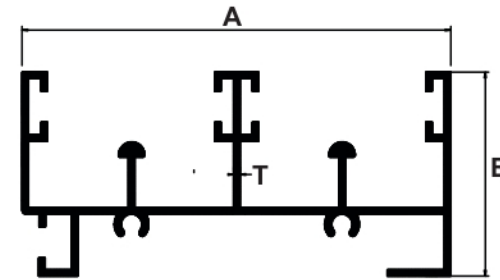

Sr. No.	Section No.	A	B	T	Wt Range Kgs/12ft
1	20092	62.00	29.50	0.75	1.700-1.800
2	20093	62.00	29.50	0.95	2.240-2.340
3	20094	62.00	29.50	1.45	3.350-3.450

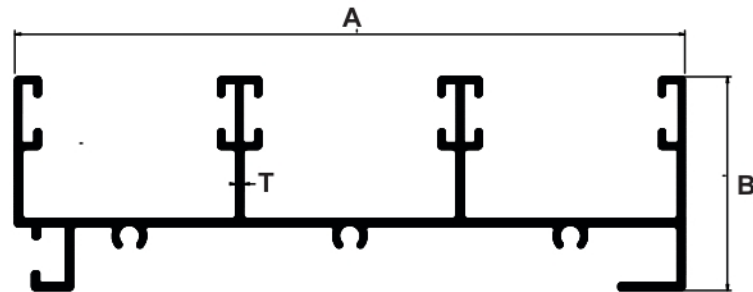

Sr. No.	Section No.	A	B	T	Wt Range Kgs/12ft
1	20089	92.50	29.50	0.85	2.450-2.550
2	20090	92.50	29.50	1.10	2.650-2.750
3	20091	92.50	29.50	1.45	3.800-3.900

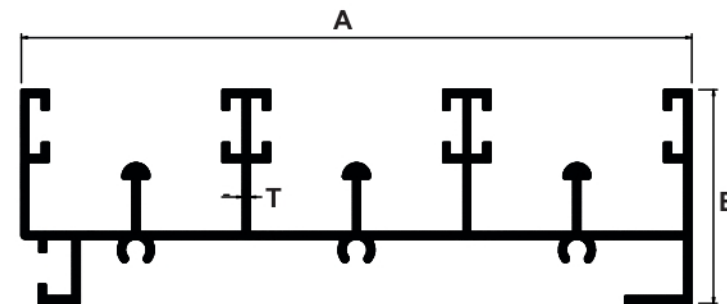

Sr. No.	Section No.	A	B	T	Wt Range Kgs/12ft
1	20095	92.50	29.50	0.85	2.550-2.650
2	20096	92.50	29.50	1.00	3.100-3.200
3	20097	92.50	29.50	1.45	4.100-4.200

ALL DIMENSIONS IN MM. • WEIGHT TOLERANCES ± 7 TO 10%



20MM WINDOW SECTION

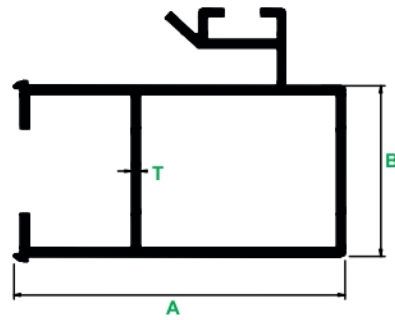

Sr. No.	Section No.	A	B	T	Wt Range Kgs/12ft
1	20098	38.80	20.00	0.75	1.200-1.300
2	20099	38.80	20.00	0.98	1.400-1.500
3	20100	38.80	20.00	1.45	1.750-1.850

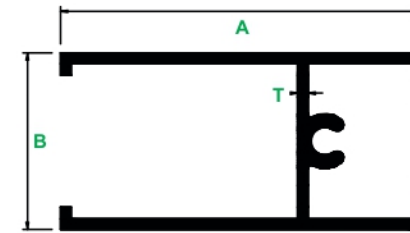

Sr. No.	Section No.	A	B	T	Wt Range Kgs/12ft
1	20104	38.80	20.00	0.75	1.050-1.150
2	20105	38.80	20.00	1.22	1.400-1.500
3	20106	38.80	20.00	1.45	1.650-1.750

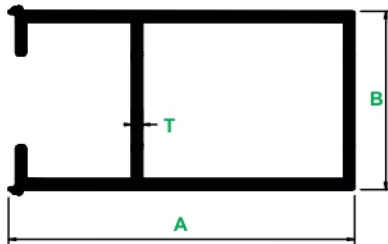

Sr. No.	Section No.	A	B	T	Wt Range Kgs/12ft
1	20101	41.00	20.00	0.85	1.050-1.150
2	20102	41.00	20.00	1.20	1.400-1.500
3	20103	41.00	20.00	1.45	1.670-1.770



WINDOW SECTION (SPECIAL SERIES)

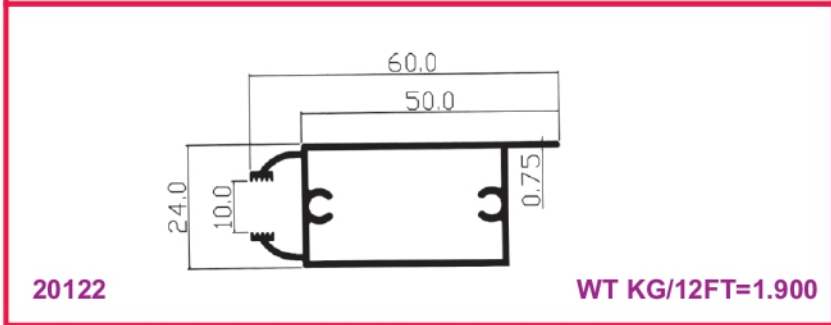
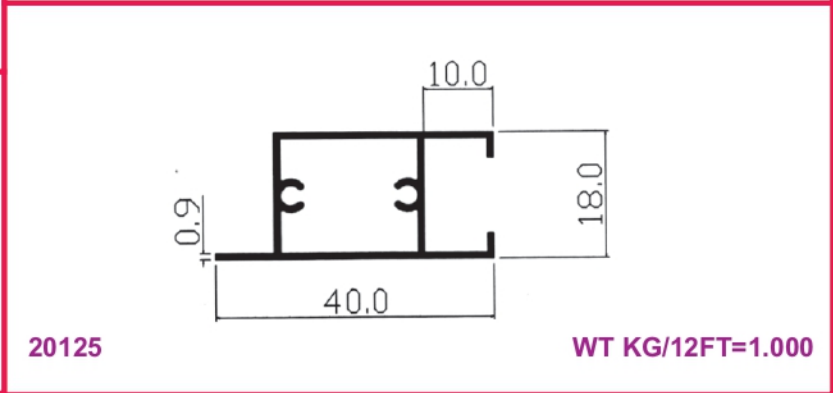
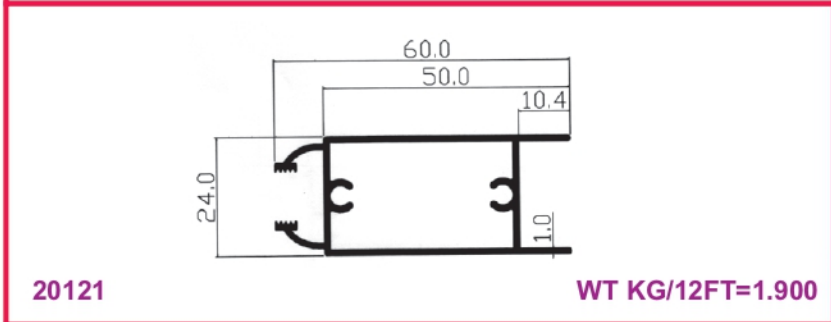
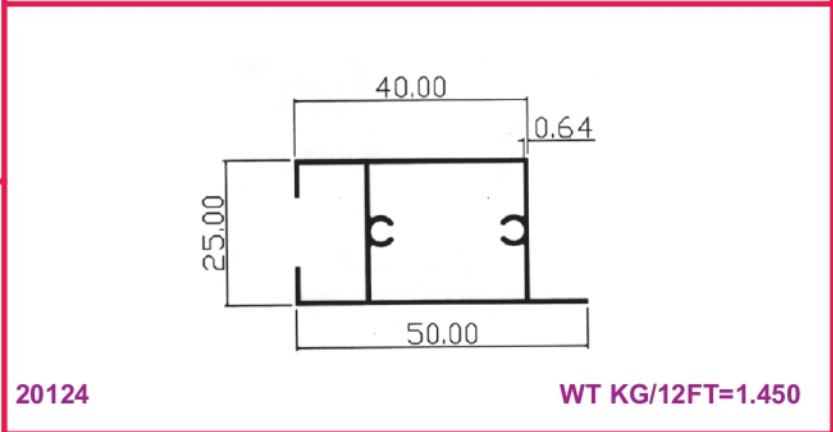
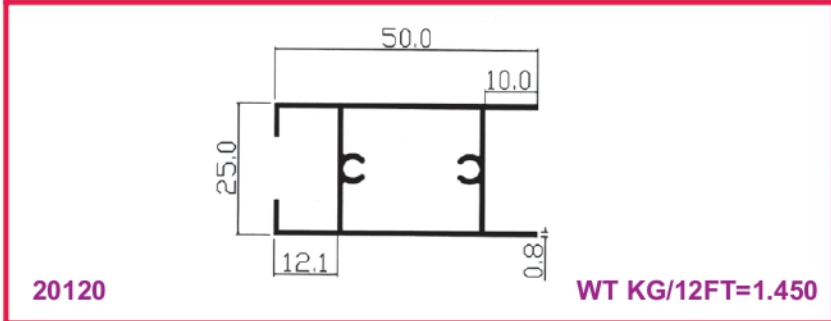
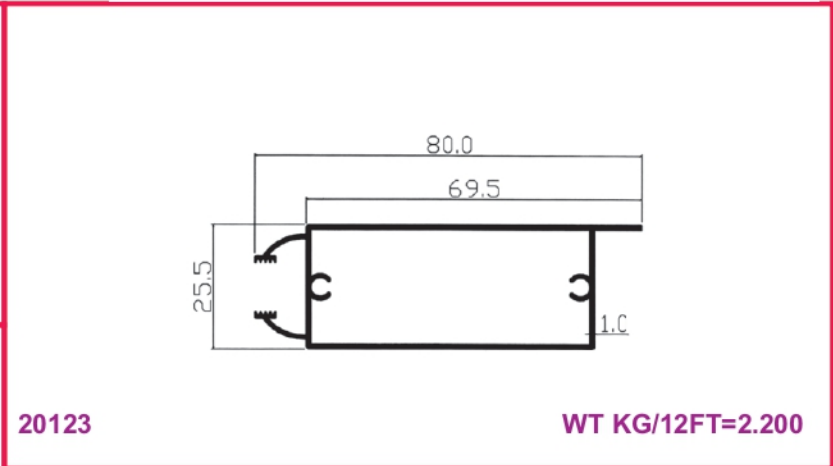
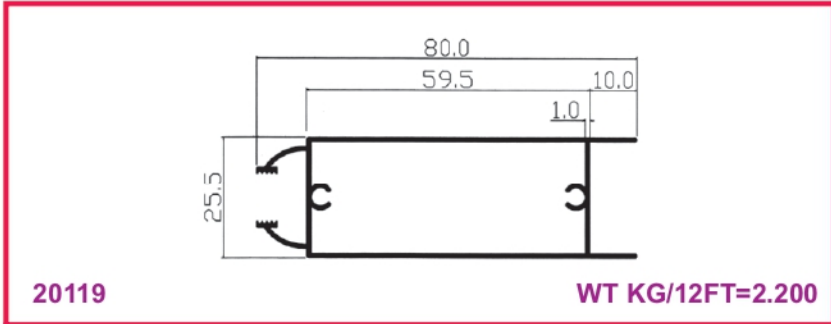

ALL DIMENSIONS IN MM. • WEIGHT TOLERANCES ± 7 TO 10%



29 MM CARDINAL SERIES

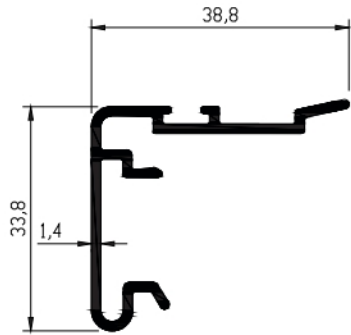

20139 WT KG/12FT=1.450

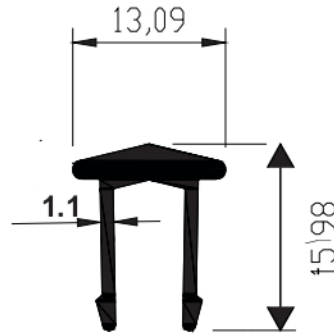

20142 WT KG/12FT=0.600

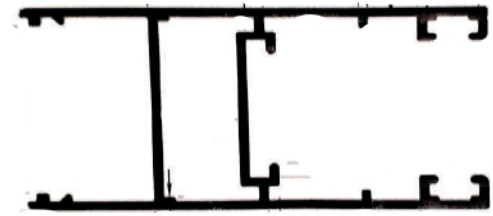

20143 WT KG/12FT=2.952

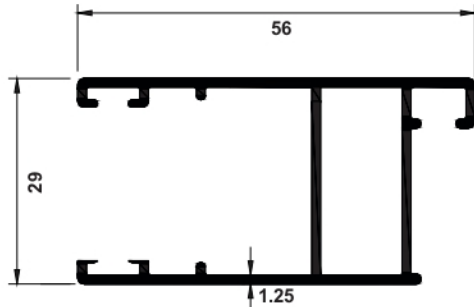

20140 WT KG/12FT=2.250

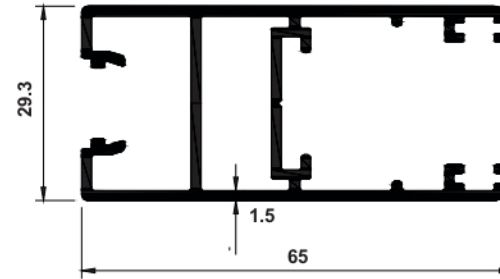

20144 WT KG/12FT=3.560

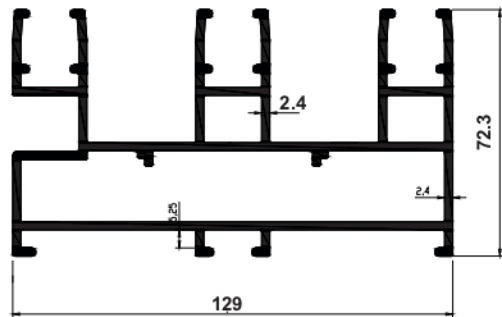

20141 WT KG/12FT=6.790

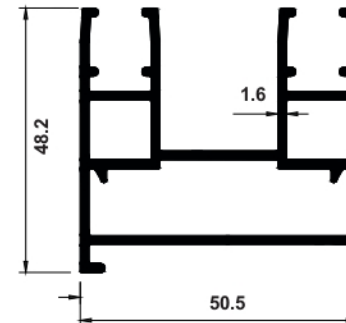

20145 WT KG/12FT=4.370

ALL DIMENSIONS IN MM. • WEIGHT TOLERANCES ± 7 TO 10%



29 MM CARDINAL SERIES

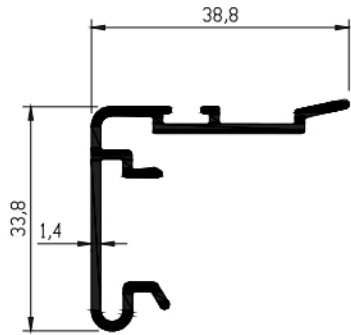

20139 WT KG/12FT=1.450

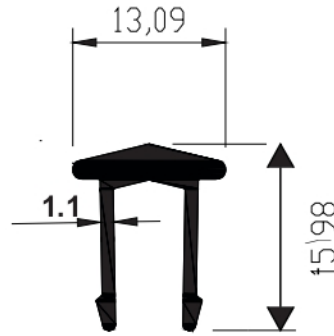

20142 WT KG/12FT=0.600

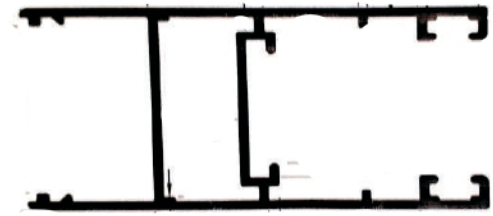

20143 WT KG/12FT=2.952

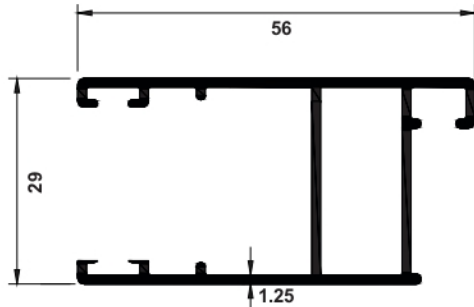

20140 WT KG/12FT=2.250

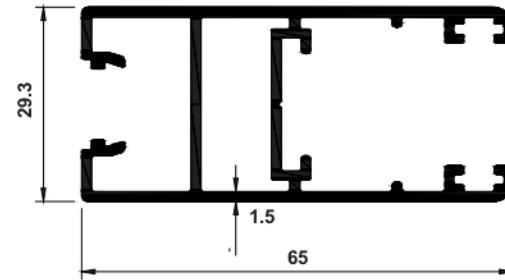

20144 WT KG/12FT=3.560

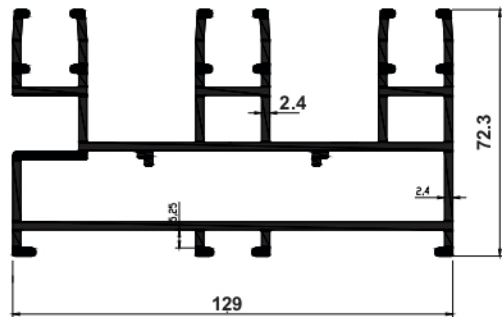

20141 WT KG/12FT=6.790

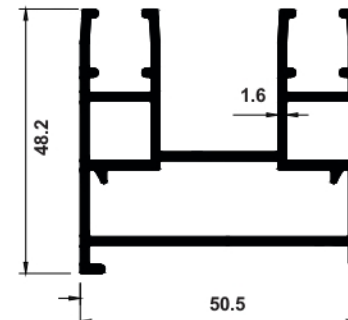

20145 WT KG/12FT=4.370

ALL DIMENSIONS IN MM. • WEIGHT TOLERANCES ± 7 TO 10%



OPENABLE WINDOW SECTIONS (Z Series)

Openable Fram

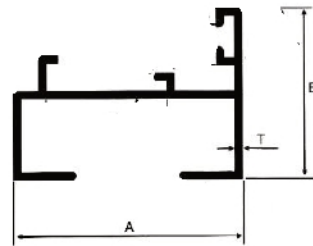

Sr. No.	Section No.	A	B	T	Wt Range Kgs/12ft
1	20146	42.00	31.00	1.50	1.800-2.100

Openable Mulian

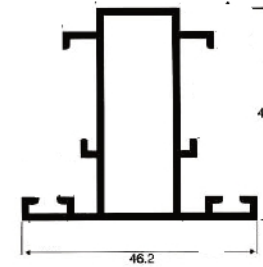

Sr. No.	Section No.	A	B	T	Wt Range Kgs/12ft
1	20148	46.20	42.00	1.20	2.190-2.390

Openable Shutter

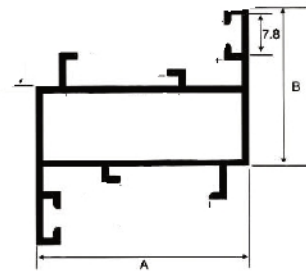

Sr. No.	Section No.	A	B	T	Wt Range Kgs/12ft
1	20147	42.00	31.20	1.20	2.200-2.400

Openable Clip

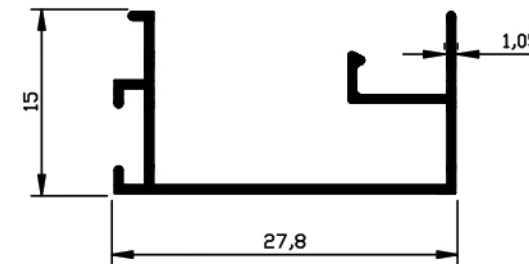

Sr. No.	Section No.	A	B	T	Wt Range Kgs/12ft
1	20149	27.80	15.00	1.05	0.770-0.870



SINTEX SECTION/DOOR FRAM SECTION

Sintex H

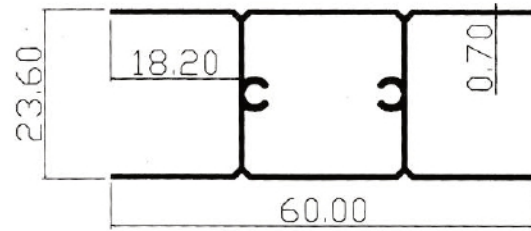

20154

WT KG/12FT=1.250

Samosa Section

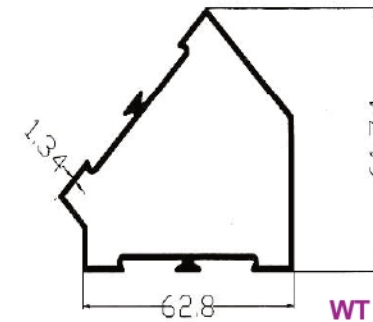

20156

WT KG/12FT=3.200

Sintex A

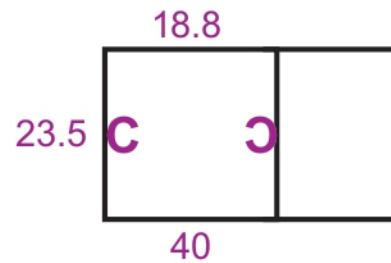

20155

WT KG/12FT=1.100

Glazing Clip

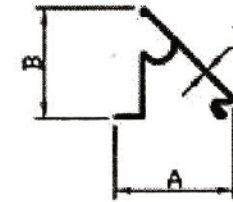

Sr. No.	Section No.	A	B	T	Wt Range Kgs/12ft
1	20157	18.40	17.00	0.40	0.200-0.250
2	20158	18.40	17.00	0.72	0.320-0.360
3	20159	18.40	17.00	0.90	0.420-0.480



Glazing Patta

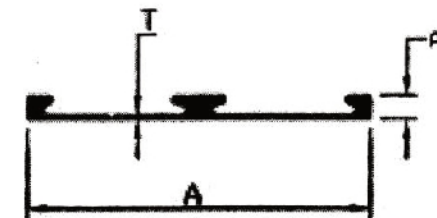

Sr. No.	Section No.	A	B	T	Wt Range Kgs/12ft
1	20160	44.40	3.60	0.80	0.600-0.700
2	20161	44.40	3.75	1.21	0.800-0.900



DOOR FRAM SECTION

2.5"X1.50" Leg Portion

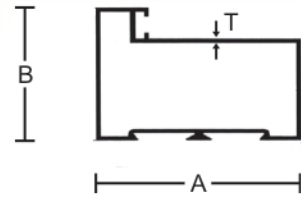

Sr. No.	Section No.	A	B	T	Wt Range Kgs/12ft
1	20178	63.50	49.50	1.10	3.000-3.200
2	20179	63.50	49.50	1.40	3.400-3.700
3	20180	63.50	49.50	1.50	3.800-4.100
4	20181	63.50	49.50	2.65	6.000-6.100
6	20182	63.50	49.50	3.00	7.100-7.200

Door Middle

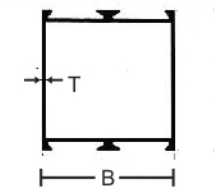

Sr. No.	Section No.	A	B	T	Wt Range Kgs/12ft
1	20197	47.00	44.45	1.00	2.00-2.100
2	20198	47.00	44.45	1.15	2.400-2.500
3	20199	83.50	44.45	1.35	3.700-3.800
4	20200	47.00	44.45	1.50	3.200-3.500
5	20201	47.00	44.75	3.00	5.300-5.400
6	20202	83.50	44.45	3.00	10.200-10.300

Door Top & Door Bottom

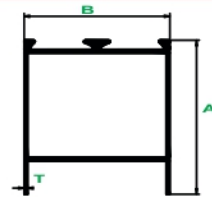

Sr. No.	Section No.	A	B	C	T	Wt Range Kgs/12ft
1	20183	47.00	44.45	10.15	1.35	2.500-2.700
2	20184	47.00	44.45	10.15	2.00	3.600-3.900
3	20185	47.00	44.45	10.00	3.00	5.200-5.300
4	20186	85300	44.45	10.00	1.50	3.800-4.100
5	20187	85.00	44.45	10.00	2.00	4.950-5.300
6	20188	85.00	44.45	10.00	3.00	7.500-8.000
7	20189	114.30	44.45	25.40	1.17	4.800-4.900
8	20190	114.30	44.45	25.40	3.00	11.500-11.600

Door Center Single

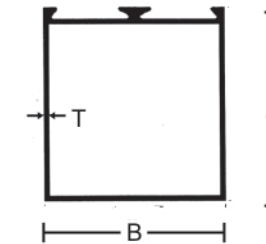

Sr. No.	Section No.	A	B	T	Wt Range Kgs/12ft
1	20203	83.05	44.45	1.35	3.500-3.600
2	20204	47.00	44.45	1.30	2.500-2.650
3	20205	47.00	44.45	1.10	2.00-2.100

Door Vertical

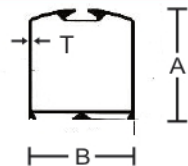

Sr. No.	Section No.	A	B	T	Wt Range Kgs/12ft
1	20191	47.00	44.45	1.15	2.500-2.600
2	20192	47.00	44.45	1.50	2.950-3.000
3	20193	47.00	44.45	3.00	5.200-5.300
4	20194	85.00	44.45	1.40	3.800-4.200
5	20195	85.00	44.45	2.00	2.150-5.500
6	20196	85.00	44.45	3.00	7.400-7.900

Corner Section

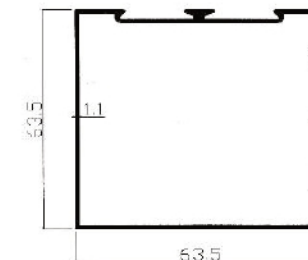

20206

WT KG/12FT=3.800