

A **WINDOW**
REFLECTS THE ESSENCE
OF **ARCHITECTURE**



ALUKING[®]
— WHERE INNOVATION MEETS EXCELLENCE —



WHY ALUMINIUM

Aluminum windows offer several advantages over wood and uPVC alternatives.

Firstly, aluminum is highly durable and corrosion-resistant, ensuring longevity even in harsh weather conditions. Its slim profiles provide maximum glass area and a sleek, modern aesthetic.

Additionally, aluminum windows are low-maintenance, requiring no painting or sealing like wood, and they won't warp or rot.

They are also environmentally friendly, as aluminum is recyclable. Furthermore, aluminum offers excellent thermal performance when combined with thermal breaks, rivaling uPVC in energy efficiency.

While wood provides a natural look, aluminum strikes a balance between aesthetics, durability, and energy efficiency, making it a versatile choice for windows





ALUKING: Your Leading Aluminium System Solutions Provider

ALUKING is a reputable and innovative aluminium system company specializing in the design, manufacturing, and distribution of high-quality aluminium sliding and casement systems. With a strong commitment to excellence, we have emerged as a prominent player in the industry, catering to diverse clientele worldwide.

Established with a vision to revolutionize the aluminium system market, ALUKING has continuously strived to deliver cutting-edge solutions that combine aesthetics, functionality, and sustainability. Our team of seasoned engineers and designers are dedicated to creating bespoke aluminium systems that meet the unique needs of each project, whether it's for residential, commercial, or industrial applications.

At ALUKING, we pride ourselves on our comprehensive product range, which includes an array of top-notch aluminium sliding and casement systems. From sleek and modern sliding doors that offer seamless integration with outdoor spaces to versatile casement windows that enhance natural ventilation, our products are engineered to elevate spaces and add value to any property.

Quality is the cornerstone of our business philosophy. We source only premium-grade materials, ensuring our aluminium systems are not only visually appealing but also durable and robust, capable of withstanding various environmental conditions. Rigorous quality control measures are implemented throughout the production process to ensure each system complies with international standards.

Our commitment to sustainability drives us to adopt eco-friendly practices in our operations. We prioritize energy-efficient designs that reduce environmental impact and help clients achieve their sustainability goals. Additionally, ALUKING actively participates in recycling initiatives to minimize waste generation and promote a greener future.

Customer satisfaction is paramount, and we continuously strive to exceed expectations. Our dedicated customer support team is readily available to assist clients with expert guidance, from product selection to installation and after-sales service. We believe in nurturing long-term partnerships with our clients, ensuring a seamless experience throughout their association with ALUKING.

Through continuous research and development, ALUKING stays at the forefront of industry trends, consistently introducing innovative aluminium system solutions that redefine spaces and inspire architectural possibilities.

Whether you are an architect, contractor, or homeowner, ALUKING offers a one-stop-shop for all your aluminium sliding and casement system needs. Join us in creating spaces that blend style, functionality, and sustainability with our exceptional aluminium system solutions. Experience the ALUKING advantage today.

Design & Technical collaboration with STAYFIX LTD. UK.

LET'S
MAKE YOUR
VIEW **WIDER**



INDEX



SLIDING
WINDOW



CASEMENT
WINDOW



CASEMENT
DOOR



BI-FOLD
WINDOW

SLIDING SYSTEM

ALUKING HS2500 SYSTEMS	06
ALUKING GS2500 SYSTEMS	10
ALUKING HS2900 SYSTEMS	14
ALUKING GS2900 SYSTEMS	18

SLIDING PREMIUM SERIES

ALUKING HS3200 SYSTEMS	22
ALUKING HS3600 SYSTEMS	26
ALUKING GS3600 SYSTEMS	30
ALUKING HS4200 SYSTEMS	34

SLIDING PREMIUM MINIMAL SERIES

ALUKING H300 MINIMAL SYSTEMS	38
ALUKING H360 MINIMAL SYSTEMS	42
ALUKING H400 MINIMAL SYSTEMS	48

CASEMENT SERIES

ALUKING CS3000 SYSTEMS	52
ALUKING CS6000 SYSTEMS	56

CASEMENT PREMIUM DOOR SERIES

ALUKING DS6000 SYSTEMS	62
-------------------------------------	-----------

HS2500

SLIDING SYSTEMS

This Marvellously Designed Combination System is Ideal Solution For Economy System Which Meets Highest Point of Aesthetic Performance and Functionality. This System is Having Highest Standards in Terms of Elegance, Comfort, and Performance. Sleek Interlocking Profile adds A lots of Glamour in this System.

Sliding with Grill option Increases Security Perspective and additional Track Provides Option for Mosquito Sash Option in This System. This Systems is Perfect Solution for Economy Projects.

EPDM Gasket in Interlocking Profile Increases Sound proofing and Dust Proofing and Proper Euro Groove of Locking Enhance Security Perspective and Nylon Roller Enhance Smoothness of Sliding and other Hardware Makes This System Complete..

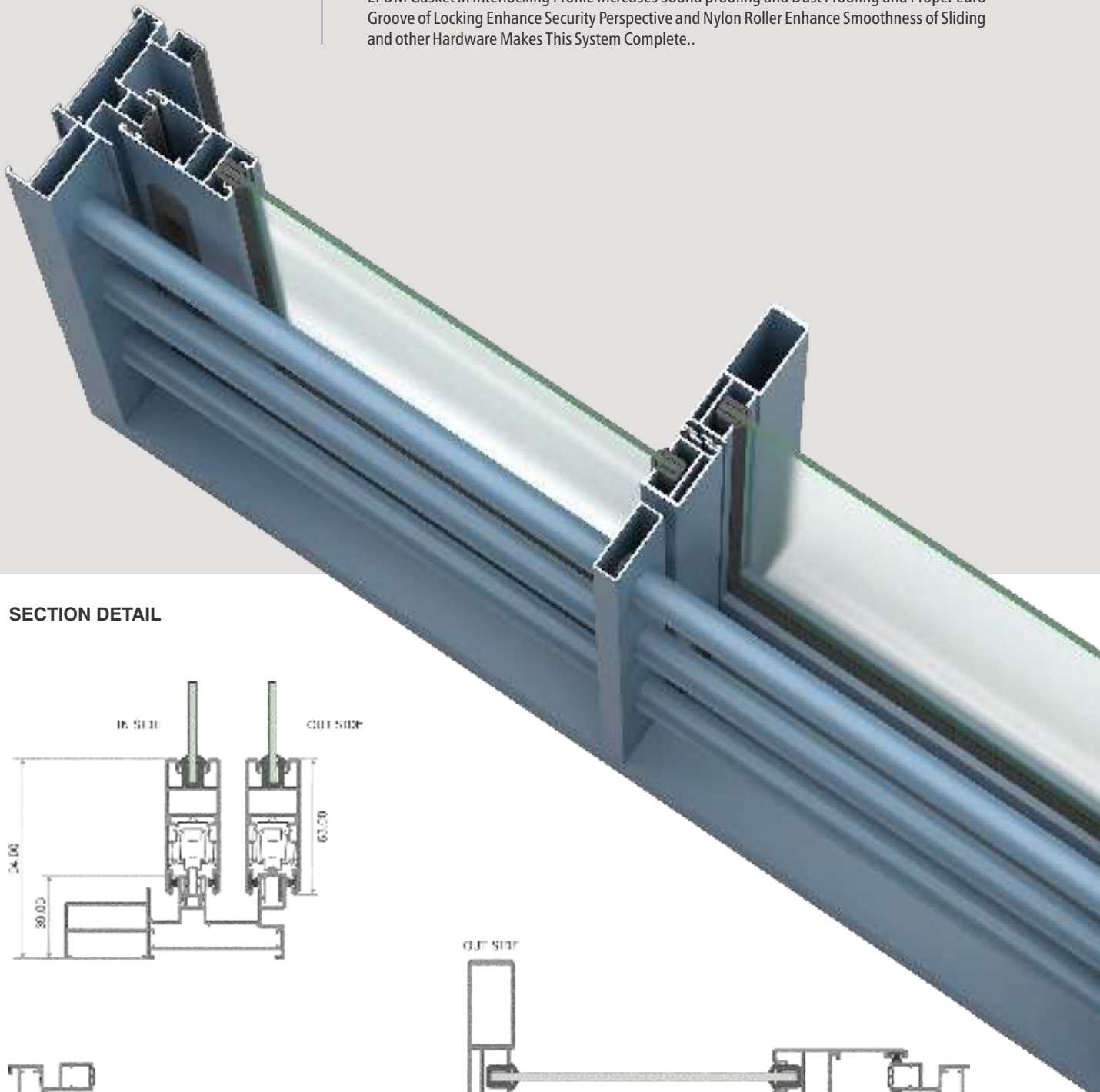

SECTION DETAIL

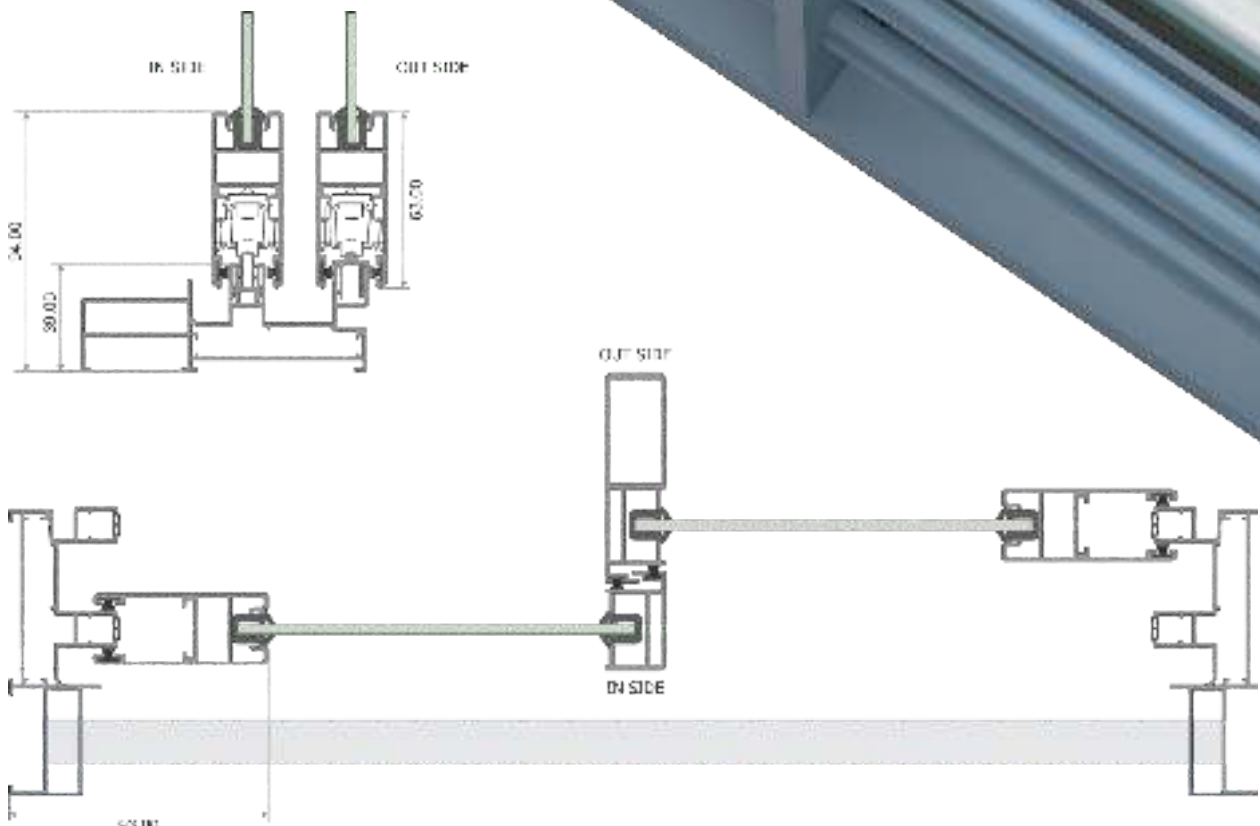

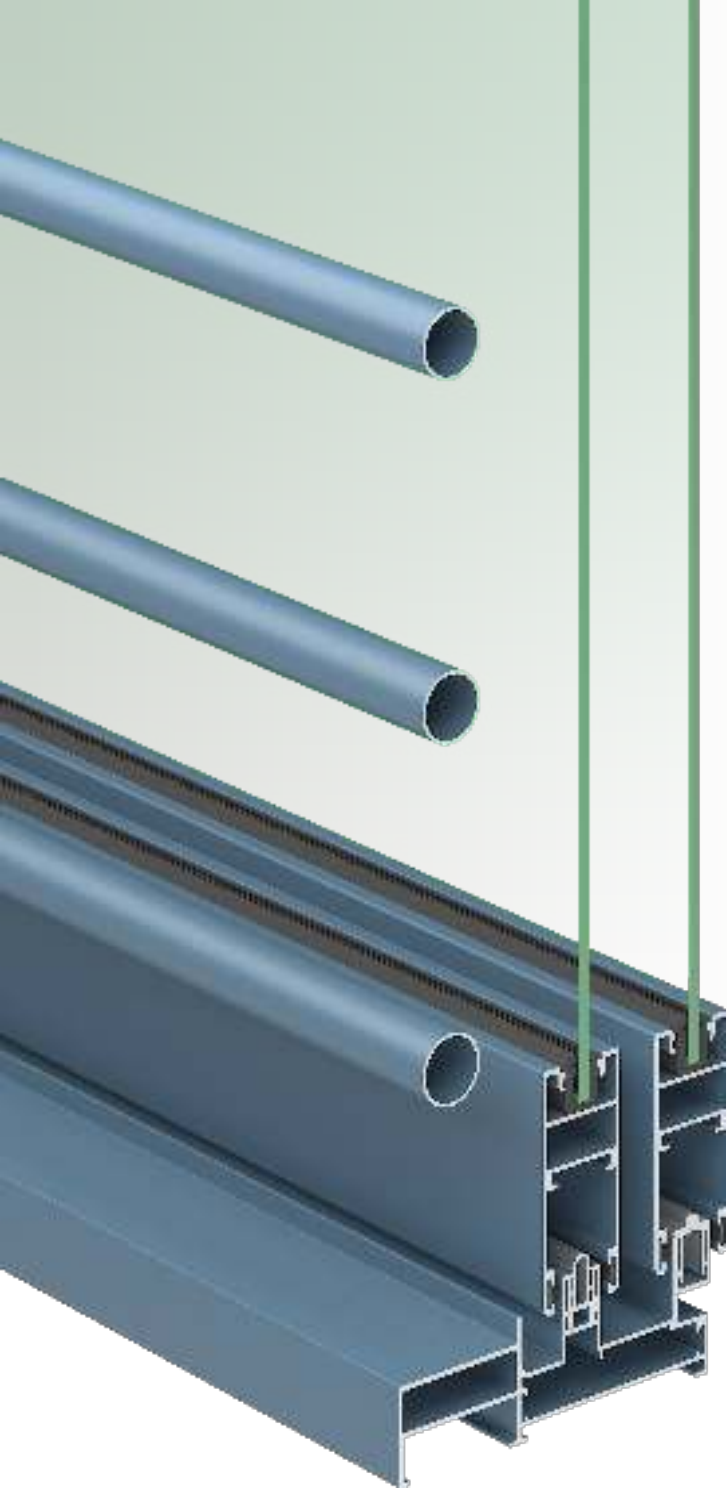

TECHNICAL SPECIFICATION

▶ Frame Height	: 42.5mm
▶ 3-track Outer Width	: 101mm
▶ 2-track Outer Width	: 65mm
▶ Interlocking Sightline	: 21mm
▶ Roller Capacity	: Up to 80Kg/Pair
▶ Glass Thickness	: 5 to 8mm
▶ Max Shutter Height	: 1800mm
▶ Sliding With Grill Option	: Available
▶ Additional Mosquito Track	: Available
▶ Top & Bottom Fix Option	: Available

WATER DRAINAGE

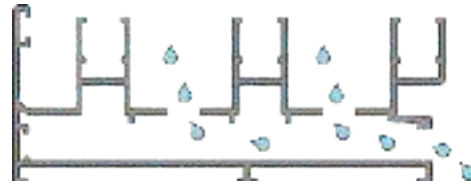

AIR
PERMEABILITY



SOUND
INSULATION



WATER
TIGHTNESS



WIND
RESISTANCE



IMPACT
RESISTANCE



AIR
TIGHTNESS

SYSTEM SPECIFICATION

- Flexible Design
- Design for Bungalows & Project
- Perfect Solution for Small Opening
- Combination Of Sliding & Fix Windows
- Sleeker & Studier
- Smooth & Effortless During Operation
- Security Grill Option Available
- Single & Multi Point Locking
- SS304 U-Groove Bottom Rail For Smooth Sliding
- Reinforcement Interlock Available To Resist Wind Pressure In High Rise
- Fix & Adjustable Rollers Available
- Provision For Mosquito Mesh
- Applicable To Buildings With Special Mobility Characteristic.

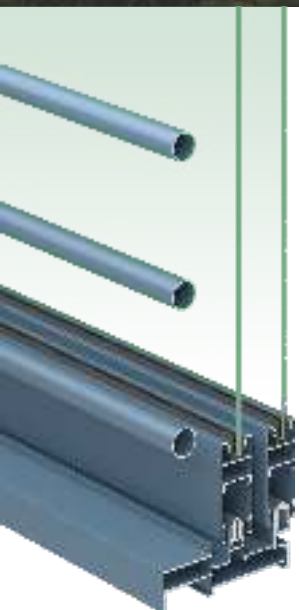

- Wide Range Of Locking Handles.
- Fix & Adjustable Rollers Up To 80 Kg Capacity.
- Single Point Auto Lock.
- Euro Groove Multi Point Locking System
- Customized Plastic Components Like Interlock Cap, Lock Guide, & Buffer Bump Stop Etc.
- Non Return Drainage Solution
- All Size Of Glass Packers And Frame Packers
- Heavy Duty Adjustable Corner Cleat For Hair Line Joint.
- Microwave Cured EPDM Rubber Gasket For All Glass Size
- All Hardware Is Having A 10 Years Of Operational Guarantee

3 TRACK - 6 SHUTTER

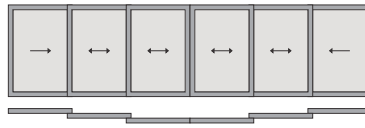

2 TRACK - 3 SHUTTER (X-2X-X)

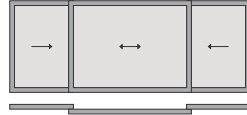

2 TRACK - 4 SHUTTER

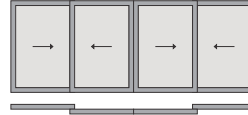

2 TRACK - 2 SHUTTER

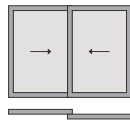

3 TRACK - 3 SHUTTER

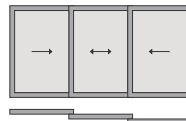

3 TRACK - 4 SHUTTER + 2 MESH SHUTTER

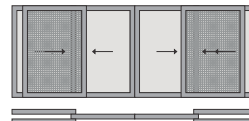

3 TRACK - 2 SHUTTER + 1 MESH SHUTTER

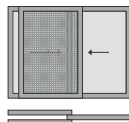

3 TRACK - 3 SHUTTER + 2 MESH SHUTTER

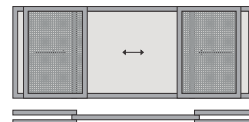

BOTTOM FIX TYPOLOGY

3 TRACK - 6 SHUTTER

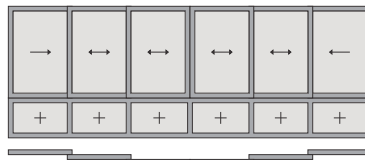

2 TRACK - 3 SHUTTER (X-2X-X)

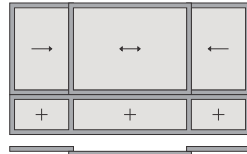

2 TRACK - 4 SHUTTER



2 TRACK - 2 SHUTTER

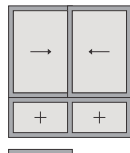

3 TRACK - 3 SHUTTER

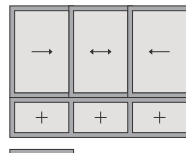

3 TRACK - 4 SHUTTER + 2 MESH SHUTTER

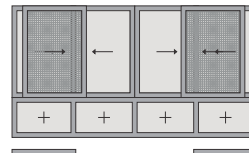

3 TRACK - 2 SHUTTER + 1 MESH SHUTTER

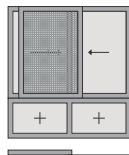

3 TRACK - 3 SHUTTER + 2 MESH SHUTTER

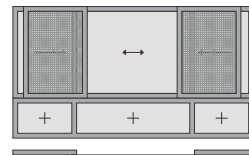

GS2500

SLIDING SYSTEMS

The GS2500 is an economical and efficient aluminum sliding system designed for various architectural applications. This versatile system offers smooth and quiet operation, making it ideal for both residential and commercial projects. Its lightweight aluminum construction ensures durability and longevity while maintaining an attractive aesthetic. The GS2500 features a user-friendly design, allowing for easy installation and maintenance. With its sleek profile and cost-effective pricing, this sliding system provides a budget-friendly solution without compromising on quality or performance, making it a popular choice for modern construction and renovation projects

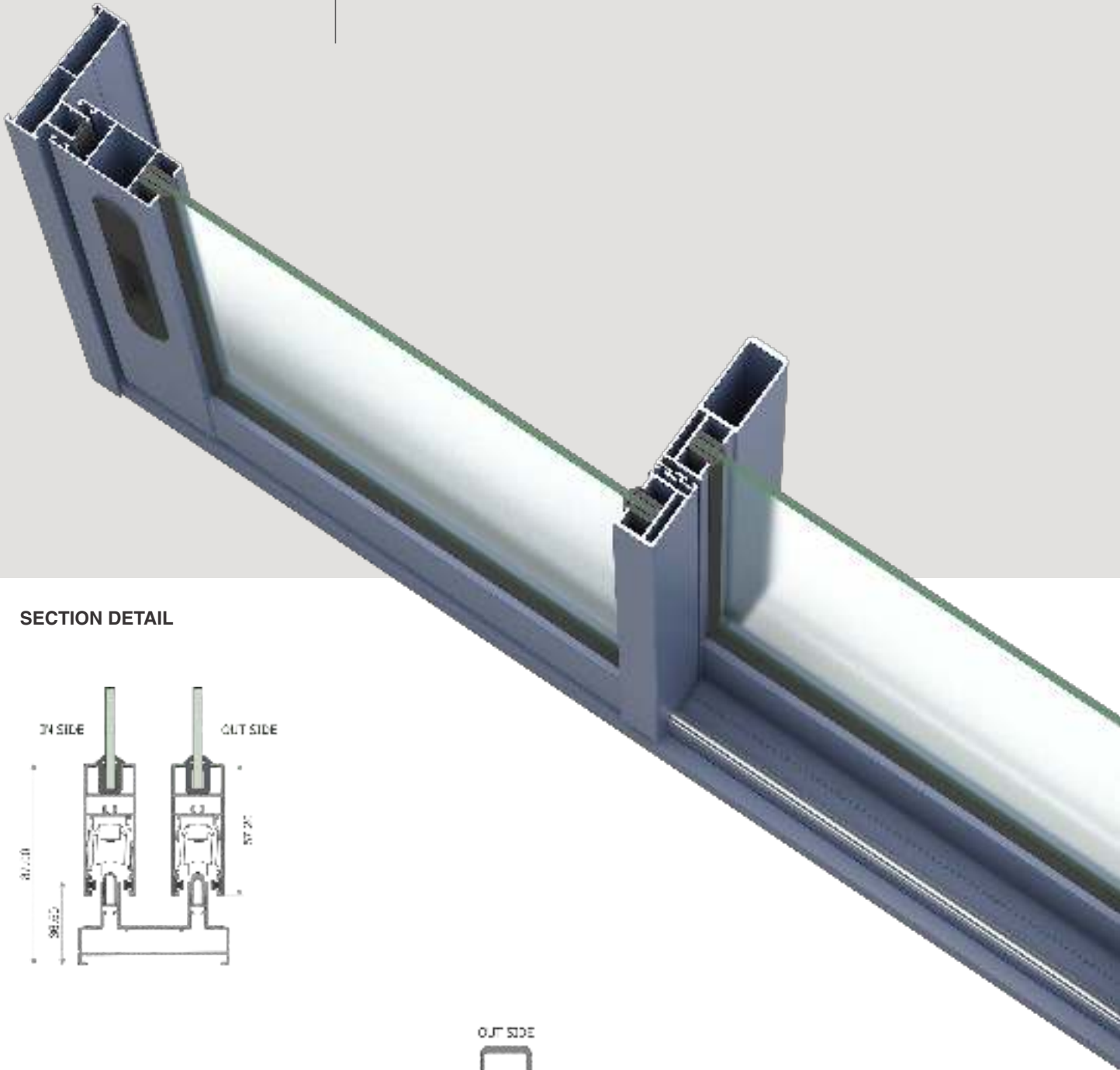

SECTION DETAIL

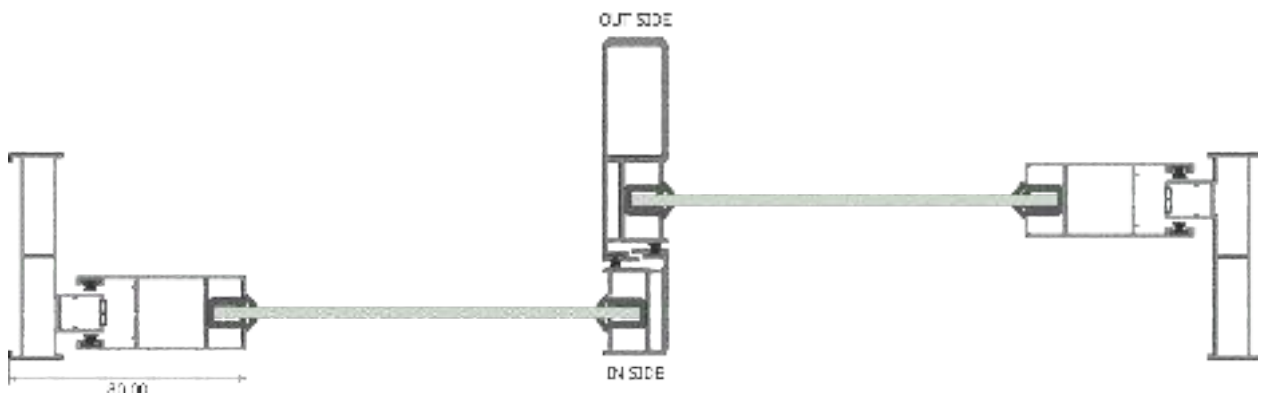
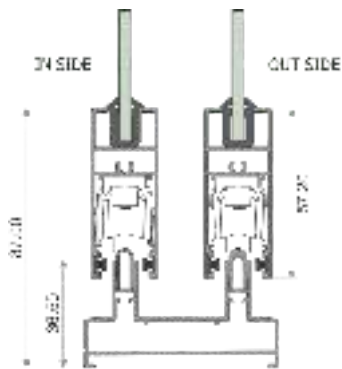

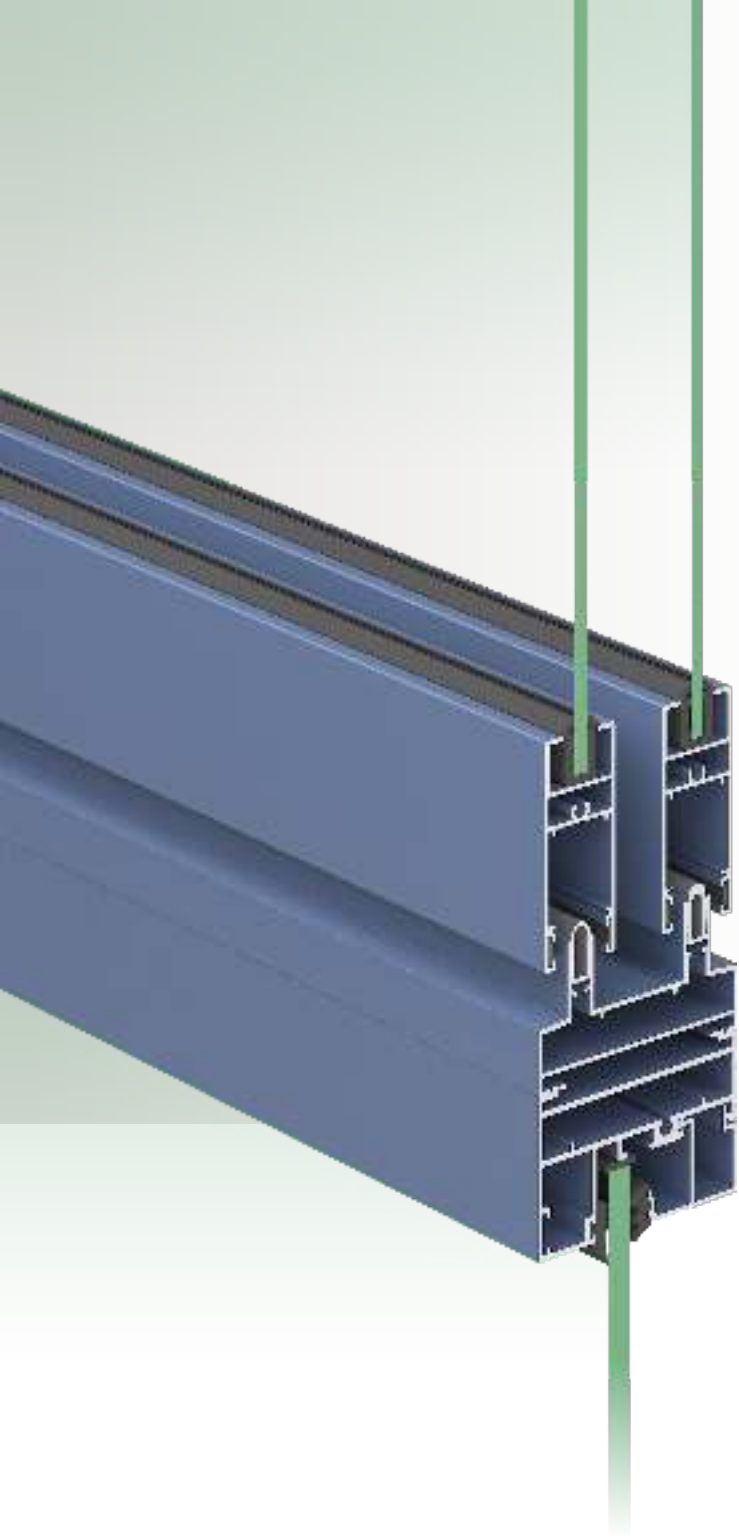

TECHNICAL SPECIFICATION

▶ Frame Height	: 36.5mm
▶ 3-track Outer Width	: 101mm
▶ 2-track Outer Width	: 65mm
▶ Interlocking Sightline	: 21mm
▶ Roller Capacity	: Up to 80Kg/Pair
▶ Glass Thickness	: 5 to 8mm
▶ Max Shutter Height	: 1800mm
▶ Mosquito Track Locking	: Available
▶ Top & Bottom Fix Option	: Available

WATER DRAINAGE

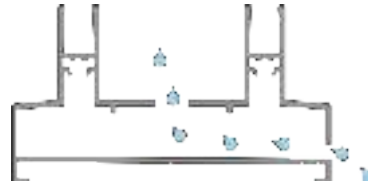

AIR
PERMEABILITY



SOUND
INSULATION



WATER
TIGHTNESS



WIND
RESISTANCE



IMPACT
RESISTANCE



AIR
TIGHTNESS

SYSTEM SPECIFICATION

- Flexible Design
- Especially For Low Rises
- Perfect Solution for Small Opening
- Combination Of Sliding & Fix Windows
- Sleeker & Studier
- Smooth & Effortless During Operation
- Single & Multi Point Locking
- SS304 U-Groove Bottom Rail For Smooth Sliding
- Reinforcement Interlock Available To Resist Wind Pressure.
- Fix & Adjustable Rollers Available
- Provision For Mosquito Mesh
- Applicable To Buildings With Special Mobility Characteristic.

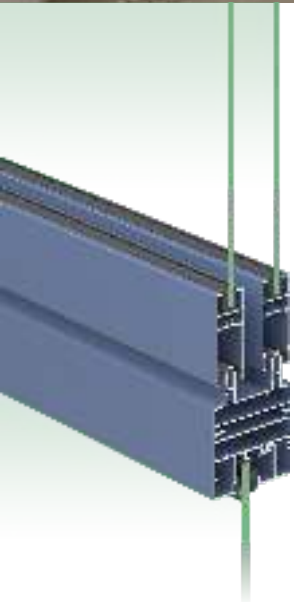

- Wide Range Of Locking Handles.
- Fix & Adjustable Rollers Up To 80 Kg Capacity.
- Single Point Auto Lock.
- Euro Groove Multi Point Locking System
- Customized Plastic Components Like Interlock Cap, Lock Guide, & Buffer Bump Stop Etc.
- Non Return Drainage Solution
- All Size Of Glass Packers And Frame Packers
- Heavy Duty Adjustable Corner Cleat For Hair Line Joint.
- Microwave Cured EPDM Rubber Gasket For All Glass Size
- All Hardware Is Having A 10 Years Of Operational Guarantee

3 TRACK - 6 SHUTTER

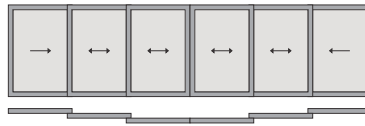

2 TRACK - 3 SHUTTER (X-2X-X)



2 TRACK - 4 SHUTTER



2 TRACK - 2 SHUTTER

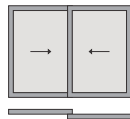

3 TRACK - 3 SHUTTER

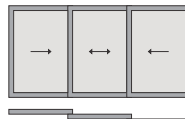

3 TRACK - 4 SHUTTER + 2 MESH SHUTTER

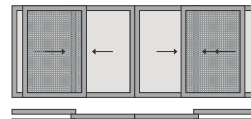

3 TRACK - 2 SHUTTER + 1 MESH SHUTTER

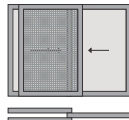

3 TRACK - 3 SHUTTER + 2 MESH SHUTTER

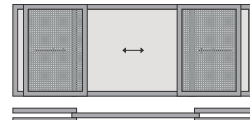

BOTTOM FIX TYPOLOGY

3 TRACK - 6 SHUTTER

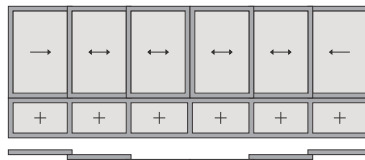

2 TRACK - 3 SHUTTER (X-2X-X)

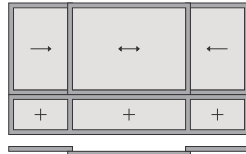

2 TRACK - 4 SHUTTER

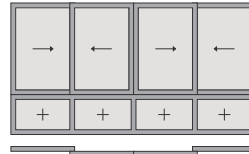

2 TRACK - 2 SHUTTER

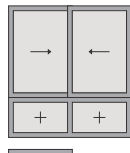

3 TRACK - 3 SHUTTER

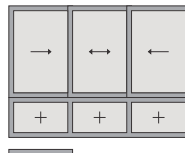

3 TRACK - 4 SHUTTER + 2 MESH SHUTTER

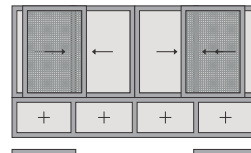

3 TRACK - 2 SHUTTER + 1 MESH SHUTTER

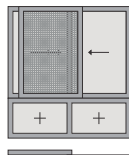

3 TRACK - 3 SHUTTER + 2 MESH SHUTTER

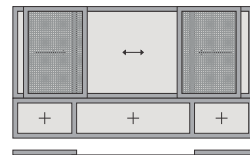

HS2900

SLIDING SYSTEMS

This Marvellously Designed combination System is Ideal Solution For Economy System Which Meets Highest Point of Aesthetic Performance and Functionality. This System is Having Highest Standards in Terms of Elegance, Comfort, and Performance. Sleek Interlocking Profile adds A lots of Glamour in this System.

This system is perfect solution for residential apartments & high rises projects.

EPDM Gasket in interlocking profile increases sound proofing and dust proofing and proper euro groove of locking enhance security perspective and nylon roller enhance smoothness of sliding and other hardware makes this system complete

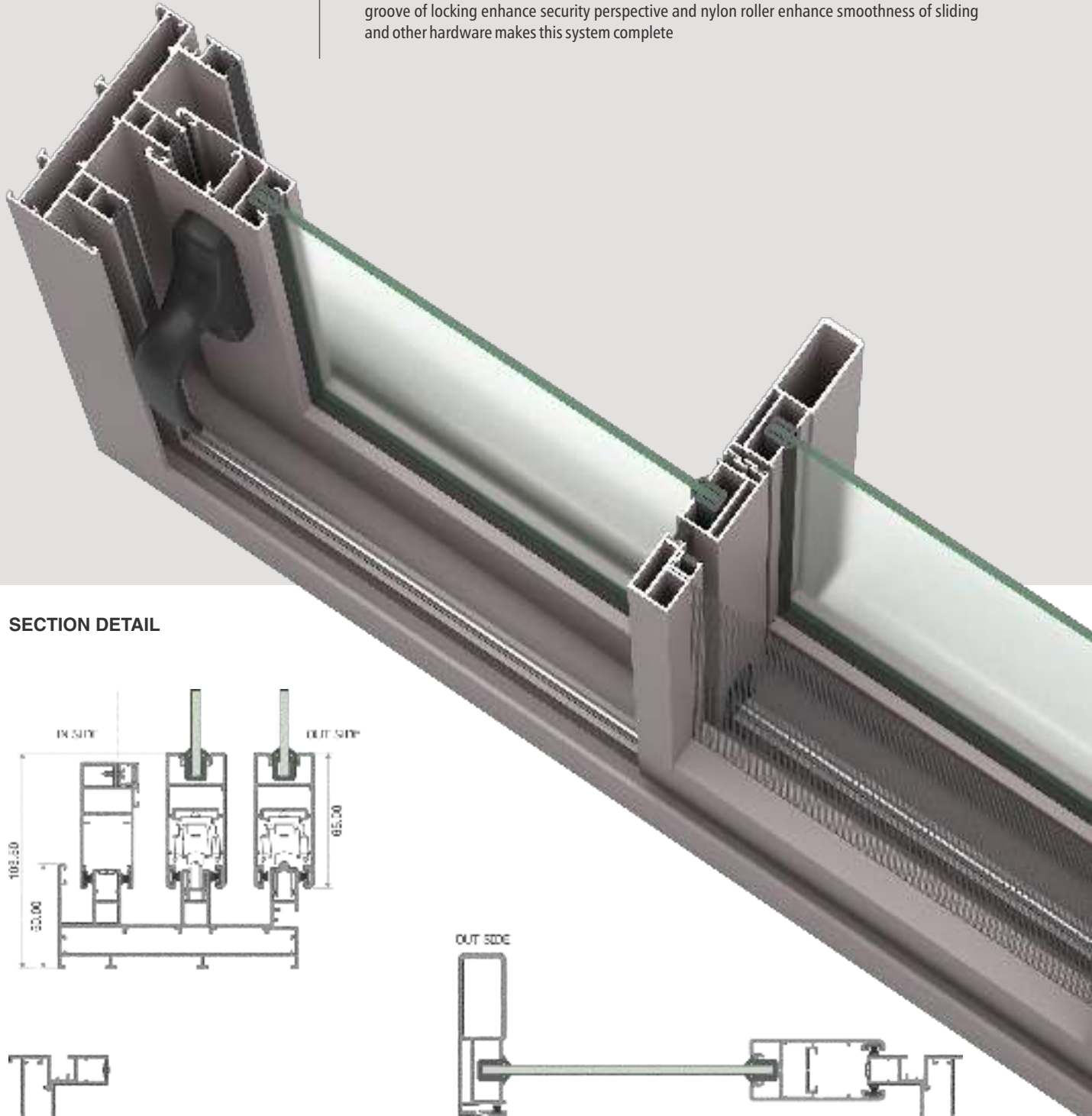

SECTION DETAIL

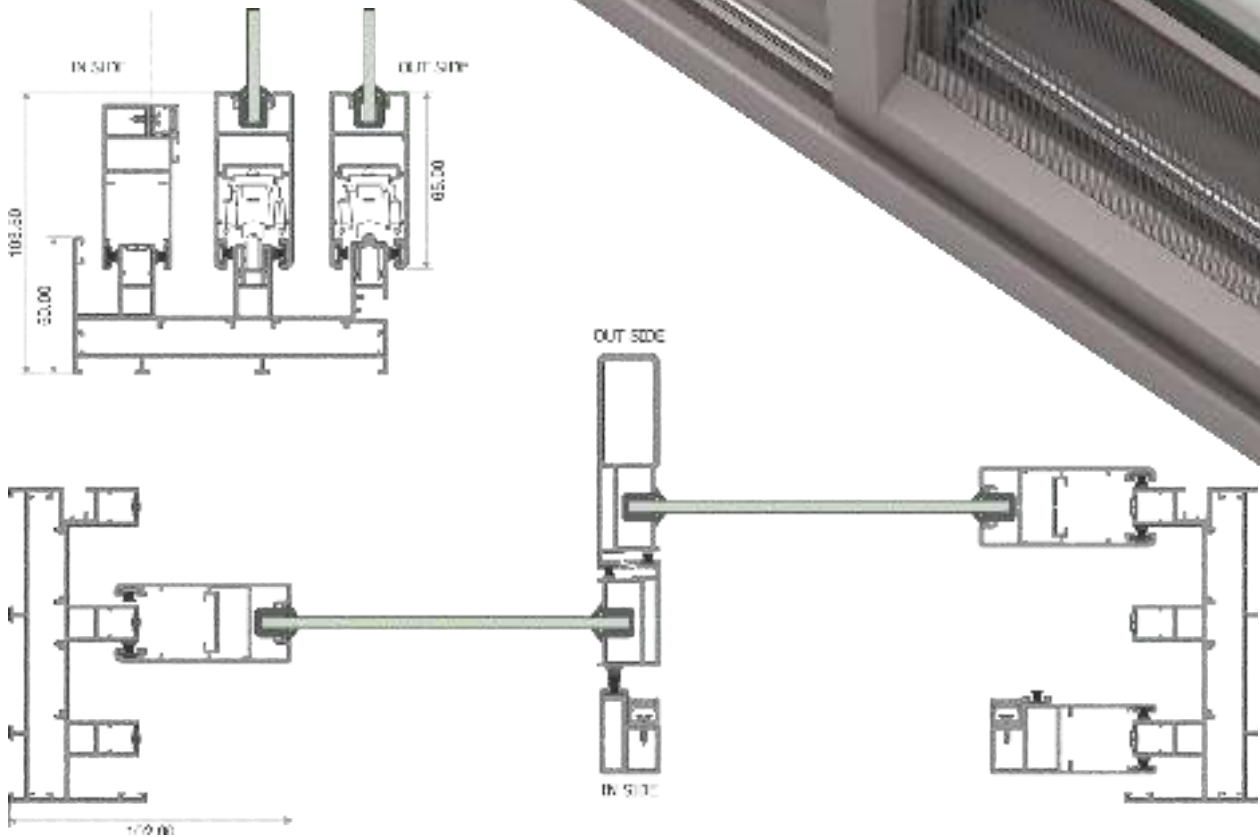

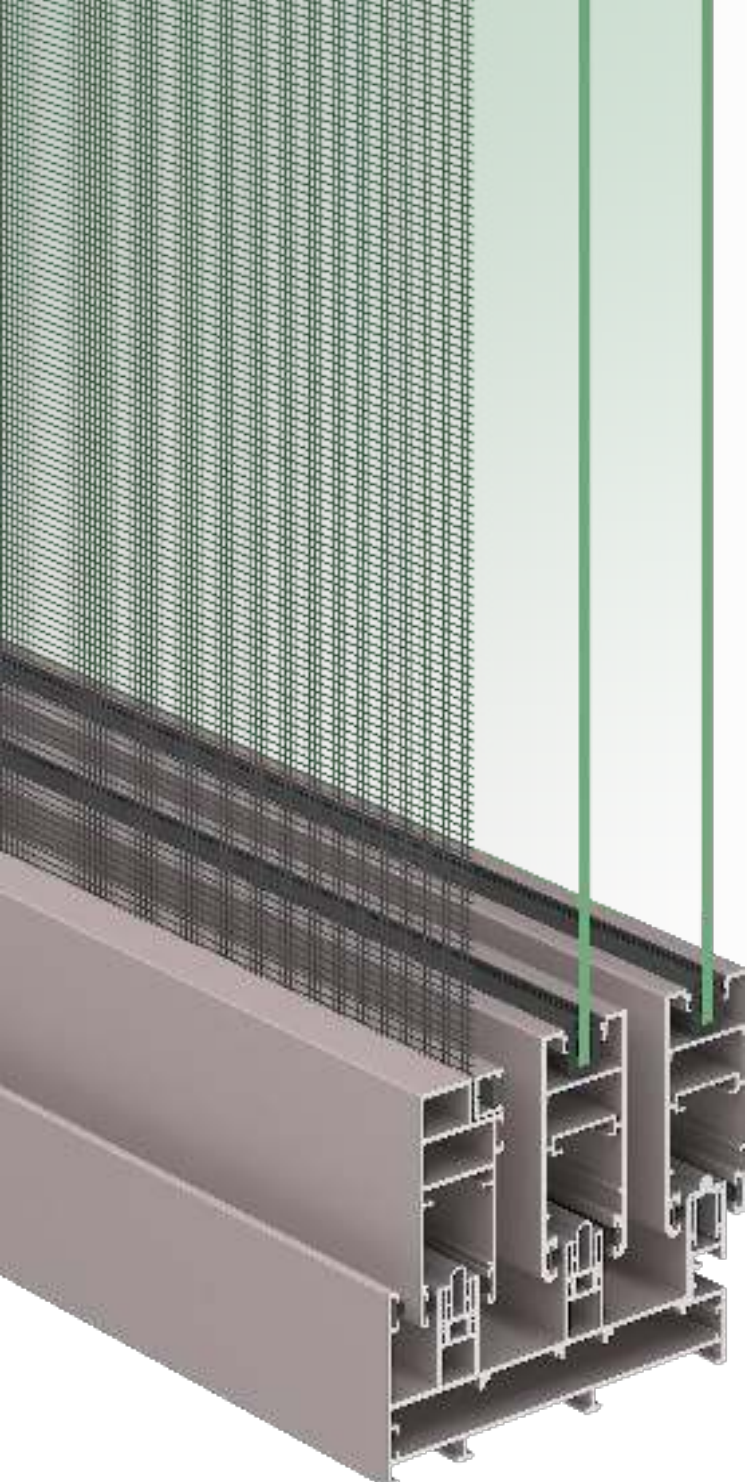

TECHNICAL SPECIFICATION

▶ Frame Height	: 50mm
▶ 3-track Outer Width	: 115mm
▶ 2-track Outer Width	: 72.5mm
▶ Interlocking Sightline	: 22.5mm
▶ Roller Capacity	: Upto 120kg/pair
▶ Glass Thickness	: 5 To 24mm
▶ Max Shutter Height	: 2100mm
▶ Top & Bottom Fix Option	: Available
▶ Locking	: Single & Multi-Point

WATER DRAINAGE

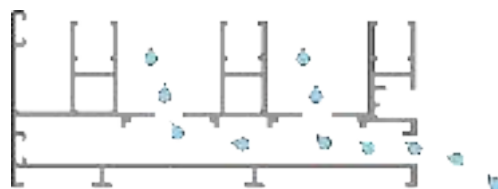

SYSTEM SPECIFICATION

- Flexible Design.
- Design for Bungalows & Project
- Combination Of Sliding & Fix Windows.
- Sleeker & Studier.
- Smooth & Effortless During Operation.
- Up To 24mm Glass Option Available.
- Single & Multi Point Locking.
- SS304 U-Groove Bottom Rail For Smooth Sliding.
- Reinforcement Interlock Available To Resist Wind Pressure In High Rise.
- Fix & Adjustable Rollers Available.
- Provision For Mosquito Mesh.
- Proper Solution For Sliding Along With Top Fix Or Bottom Fix Windows.
- One Unit Look Of Sliding And Fix Combination Increases Beauty Of This System.
- Ensures Safety when Bottom Fixed in High Rise.



AIR PERMEABILITY



SOUND INSULATION



WATER TIGHTNESS



WIND RESISTANCE



IMPACT RESISTANCE



AIR TIGHTNESS

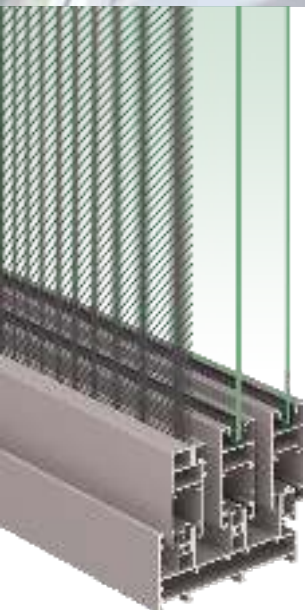

- Wide Range Of Locking Handles.
- Fix & Adjustable Rollers Up To 120 Kg Capacity.
- Single Point Auto Lock.
- Euro Groove Multi Point Locking System
- Customized Plastic Components Like Interlock Cap, Lock Guide, & Buffer Bump Stop Etc.
- Non Return Drainage Solution
- All Size Of Glass Packers And Frame Packers
- Heavy Duty Adjustable Corner Cleat For Hair Line Joint
- Microwave Cured EPDM Rubber Gasket For All Glass Size
- All Hardware Is Having A 10 Years Of Operational Guarantee

3 TRACK - 6 SHUTTER

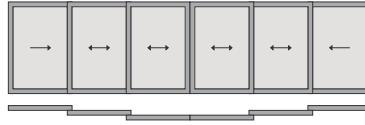

2 TRACK - 3 SHUTTER (X-2X-X)

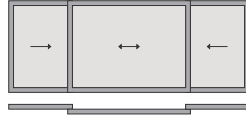

2 TRACK - 4 SHUTTER

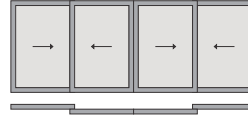

2 TRACK - 2 SHUTTER

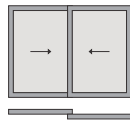

3 TRACK - 3 SHUTTER

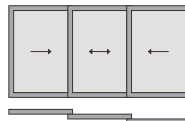

3 TRACK - 4 SHUTTER + 2 MESH SHUTTER

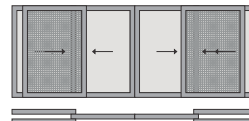

3 TRACK - 2 SHUTTER + 1 MESH SHUTTER

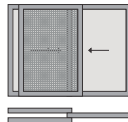

3 TRACK - 3 SHUTTER + 2 MESH SHUTTER

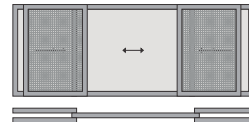

BOTTOM FIX TYPOLOGY

3 TRACK - 6 SHUTTER

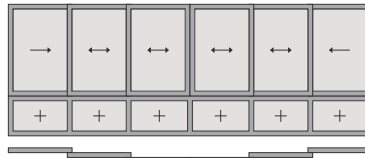

2 TRACK - 3 SHUTTER (X-2X-X)

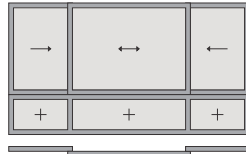

2 TRACK - 4 SHUTTER

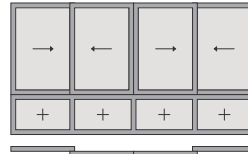

2 TRACK - 2 SHUTTER

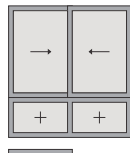

3 TRACK - 3 SHUTTER

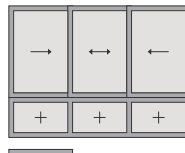

3 TRACK - 4 SHUTTER + 2 MESH SHUTTER

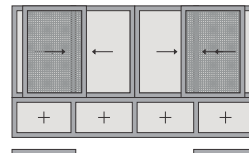

3 TRACK - 2 SHUTTER + 1 MESH SHUTTER

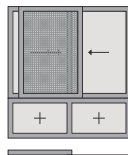

3 TRACK - 3 SHUTTER + 2 MESH SHUTTER

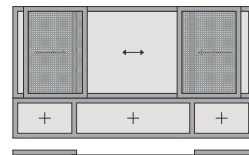

GS2900

SLIDING SYSTEMS

This Marvellously Designed System is Ideal Solution For Economy System Which Meets Highest Point of Aesthetic Performance and Functionality. This System is Having Highest Standards in Terms of Elegance, Comfort, and Performance. Sleek Interlocking Profile adds A lots of Glamour in this System.

This system is perfect solution for residential apartments & high rises projects. Sleekness of series improves glamour of building's elevation.

EPDM Gasket in interlocking profile increases sound proofing and dust proofing and proper euro groove of locking enhance security perspective and nylon roller enhance smoothness of sliding and other hardware makes this system complete

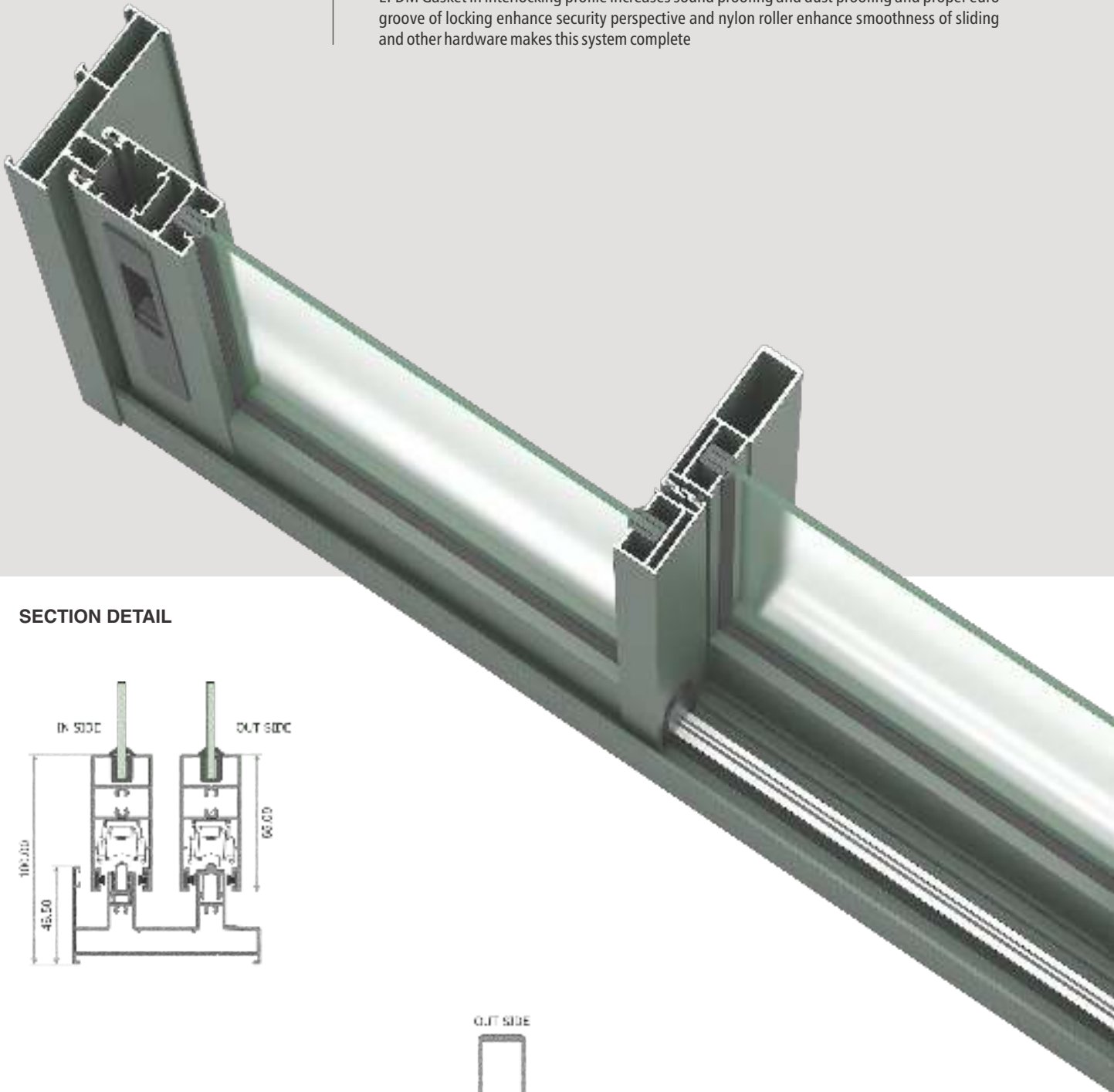

SECTION DETAIL

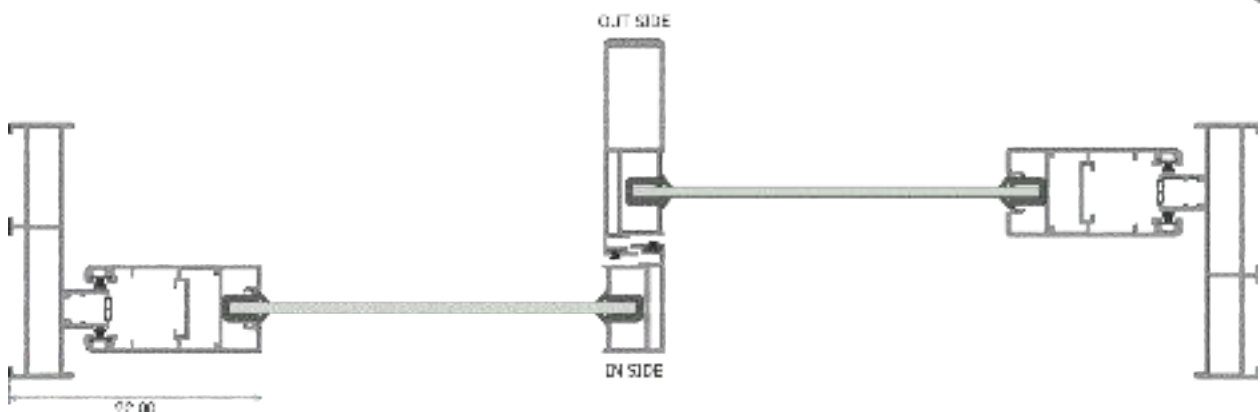
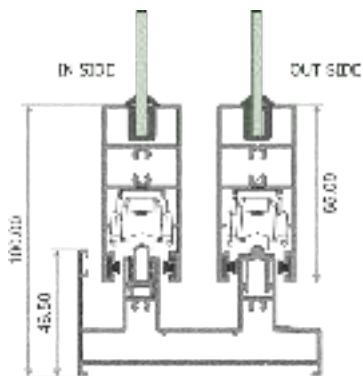

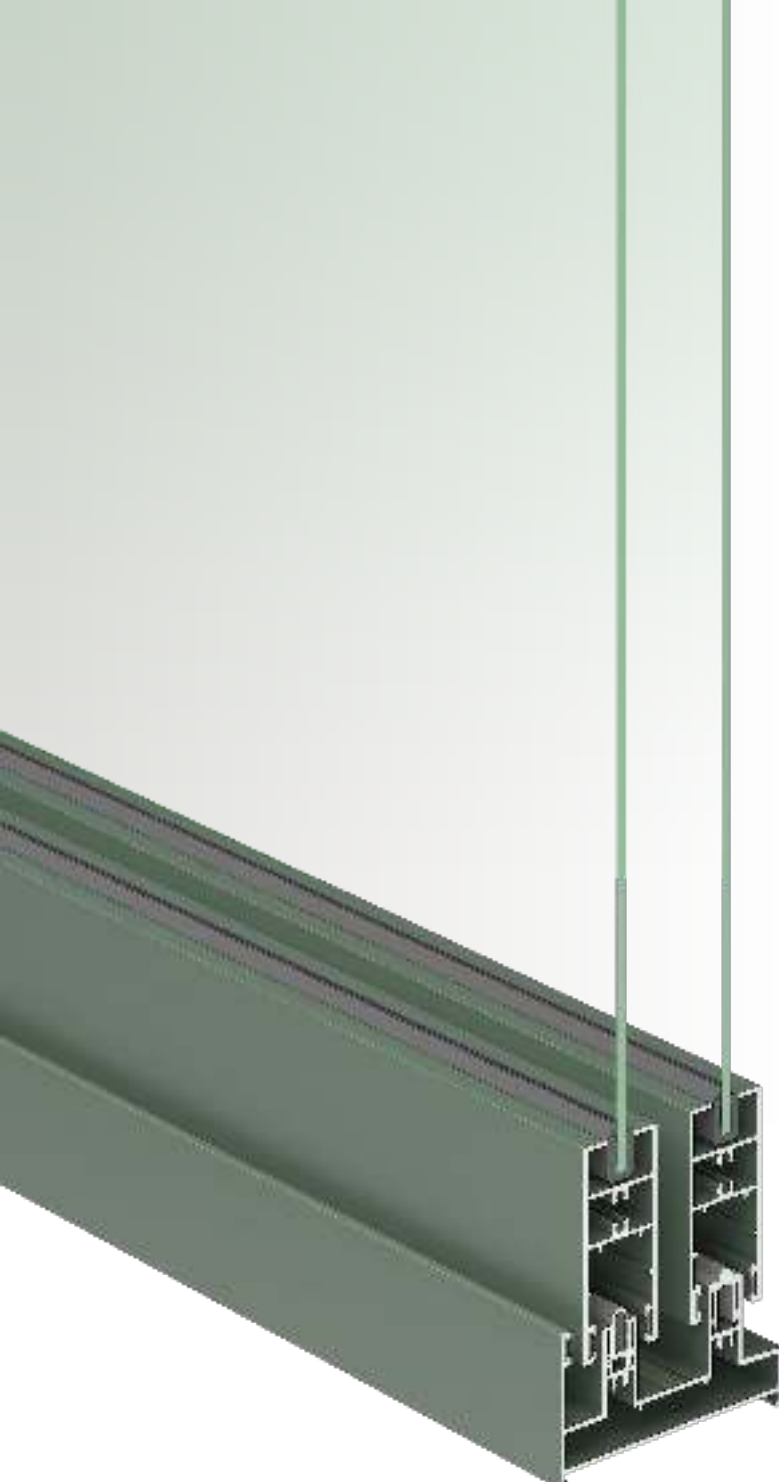

TECHNICAL SPECIFICATION

▶ Bottom Frame Height	: 46.5mm
▶ Vertical Frame Height	: 24mm
▶ 3-track Outer Width	: 136mm
▶ 2-track Outer Width	: 93.5mm
▶ Interlocking Sightline	: 22.5mm
▶ Roller Capacity	: Upto 120 Kg/pair
▶ Glass Thickness	: 5mm To 24mm
▶ Max Shutter Height	: 2100mm
▶ Slim Meeting Section	: Available
▶ Mosquito Track Locking	: Available
Profile	

WATER DRAINAGE

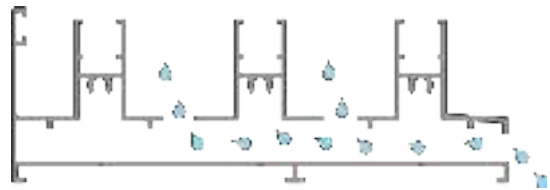

AIR PERMEABILITY



SOUND INSULATION



WATER TIGHTNESS



WIND RESISTANCE



IMPACT RESISTANCE



AIR TIGHTNESS

SYSTEM SPECIFICATION

- Flexible Design.
- Design for Bungalows & Project
- Sleeker & Studier.
- Smooth & Effortless During Operation.
- Narrow Sightings With Lateral Sill 90mm Only With 22.5mm Slimiest Interlocking Profile.
- Up To 24mm Glass Option Available.
- Single & Multi Point Locking.
- SS304 U-Groove Bottom Rail For Smooth Sliding.
- Reinforcement Interlock Available To Resist Wind Pressure In High Rise.
- Fix & Adjustable Rollers Available.
- Provision For Mosquito Mesh.
- Applicable To Buildings With Special Mobility Characteristics.
- Ease Of Use & High Functionality.

HARDWARE SPECIFICATIONS



- Wide Range Of Locking Handles.
- Fix & Adjustable Rollers Up To 120 Kg Capacity.
- Single Point Auto Lock.
- Euro Groove Multi Point Locking System
- Customized Plastic Components Like Interlock Cap, Lock Guide, & Buffer Bump Stop Etc.
- Non Return Drainage Solution
- All Size Of Glass Packers And Frame Packers
- Heavy Duty Adjustable Corner Cleat For Hair Line Joint
- Microwave Cured EPDM Rubber Gasket For All Glass Size
- All Hardware Is Having A 10 Years Of Operational Guarantee

3 TRACK - 6 SHUTTER

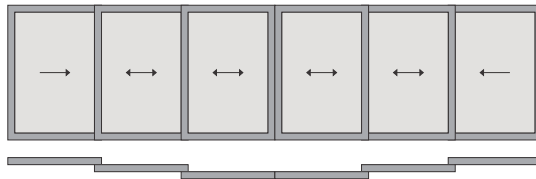

2 TRACK - 3 SHUTTER (X-2X-X)

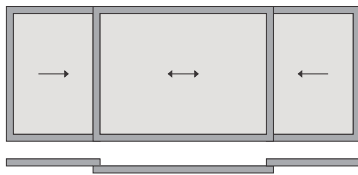

2 TRACK - 4 SHUTTER

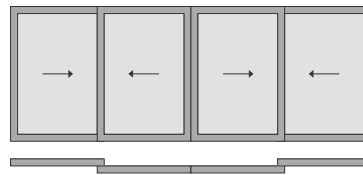

2 TRACK - 2 SHUTTER

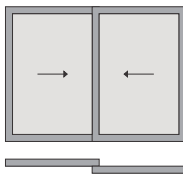

3 TRACK - 3 SHUTTER

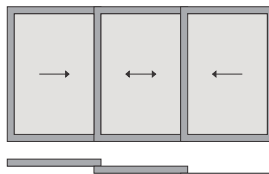

3 TRACK - 4 SHUTTER + 2 MESH SHUTTER

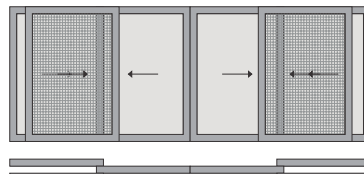

3 TRACK - 2 SHUTTER + 1 MESH SHUTTER

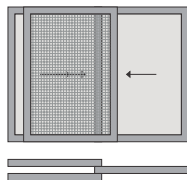

3 TRACK - 3 SHUTTER + 2 MESH SHUTTER

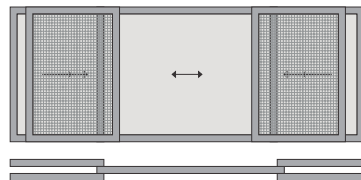

HS3200

SLIDING SYSTEMS

This Marvellously Designed Hybrid System is Ideal Solution For Economy System Which Meets Highest Point of Aesthetic Performance and Functionality. This System is Having Highest Standards in Terms of Elegance, Comfort, and Performance. Sleek Interlocking Profile adds A lots of Glamour in this System.

This system is perfect solution for residential apartments & Projects.

Sliding Shutter Along with Fix Shutter Combination Helps to Meet Economic aspect of Customer. EPDM Gasket in interlocking profile increases sound proofing and dust proofing and proper euro groove of locking enhance security perspective and nylon roller enhance smoothness of sliding and other hardware makes this system complete

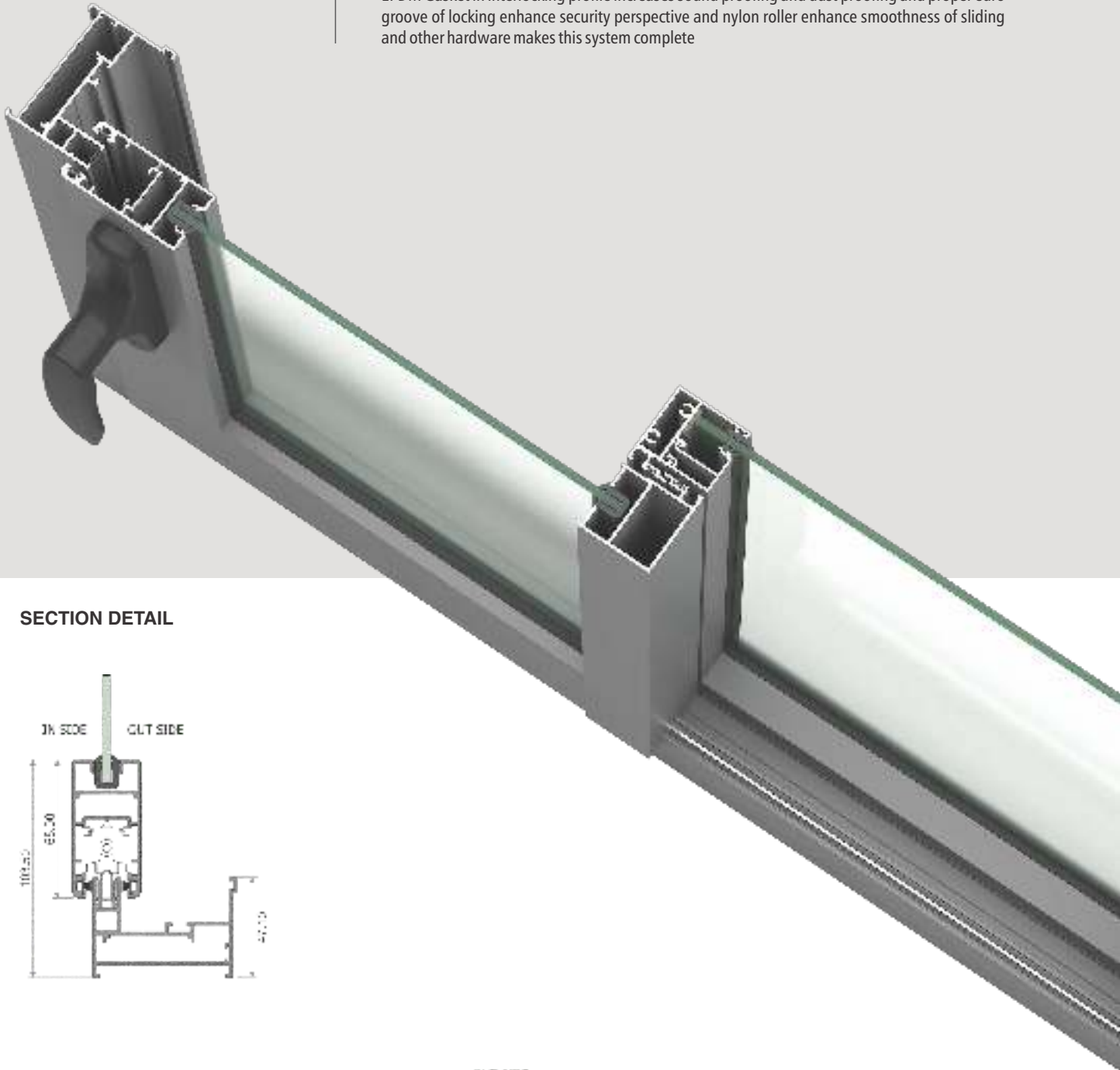

SECTION DETAIL

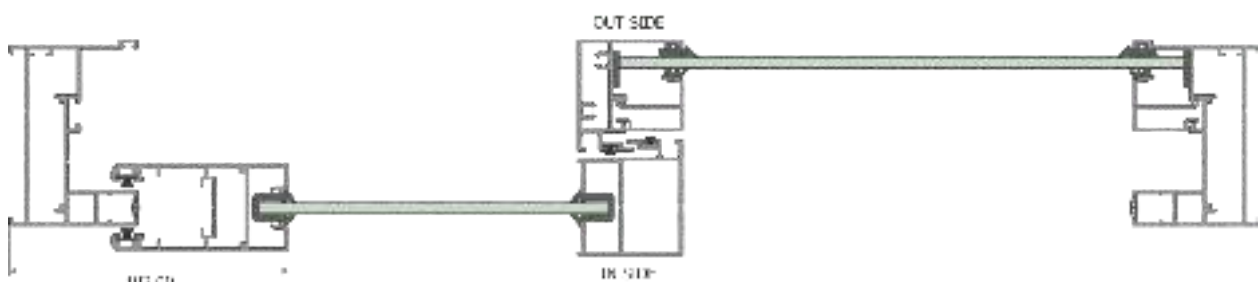
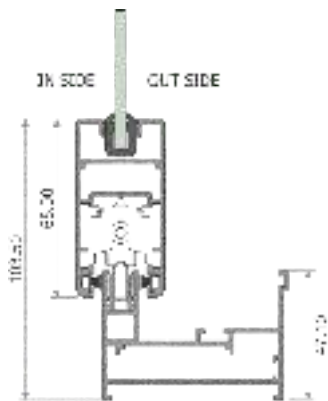

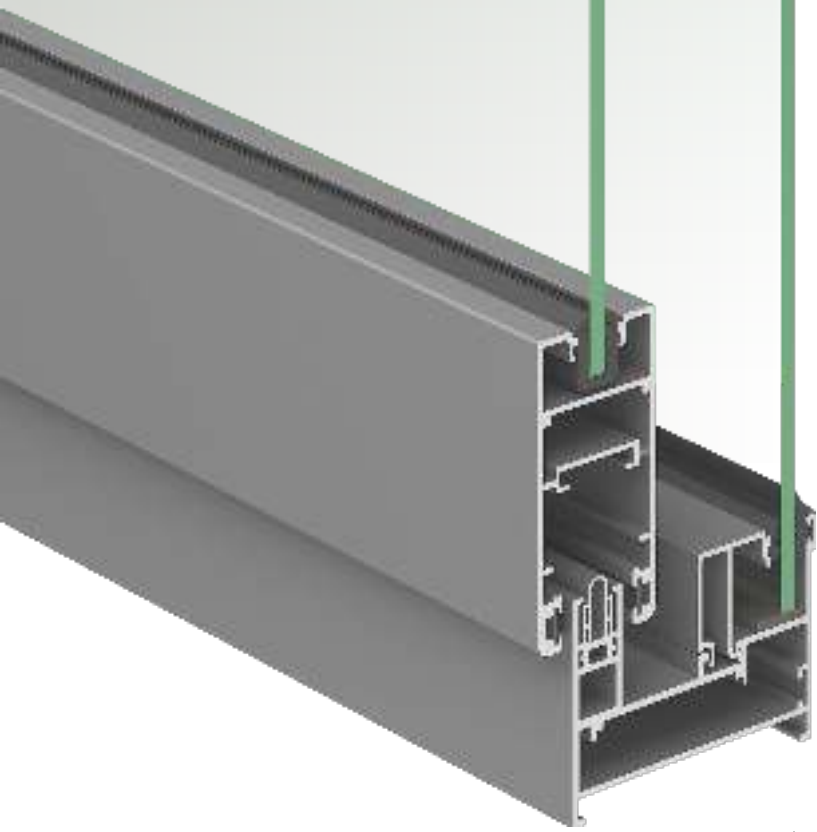

TECHNICAL SPECIFICATION

▶ Frame Height	: 47mm
▶ 3-track Outer Width	: 115.5mm
▶ 2-track Outer Width	: 70mm
▶ Interlocking Sightline	: 39mm
▶ Roller Capacity	: Upto 120kg/pair
▶ Glass Thickness	: 5 To 24mm
▶ Max Shutter Height	: 2400mm
▶ Sliding With Fix Option	: Available

WATER DRAINAGE

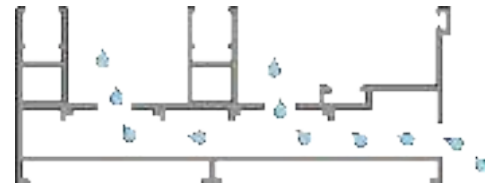

AIR PERMEABILITY



SOUND INSULATION



WATER TIGHTNESS



WIND RESISTANCE



IMPACT RESISTANCE



AIR TIGHTNESS

SYSTEM SPECIFICATION

- Hybridness Of Sliding Along With Fix Shutter Combination
- Especially For High Rises.
- Sleeker & Studier.
- Smooth & Effortless During Operation.
- Various Configuration Possible To Meet Requirement Of Even The Most Embodies Architectural Projects.
- Maintenance Free.
- Applicable To Buildings With Specials Mobility Characteristics.
- SS304 U-Groove Bottom Rail For Smooth Sliding.
- Fix & Adjustable Rollers Available.
- Provision For Mosquito Mesh.



- Wide Range Of Locking Handles.
- Fix & Adjustable Rollers Up To 120 Kg Capacity.
- Single Point Auto Lock.
- Euro Groove Multi Point Locking System
- Customized Plastic Components Like Interlock Cap, Lock Guide, & Buffer Bump Stop Etc.
- Non Return Drainage Solution
- All Size Of Glass Packers And Frame Packers
- Heavy Duty Adjustable Corner Cleat For Hair Line Joint
- Microwave Cured EPDM Rubber Gasket For All Glass Size
- All Hardware Is Having A 10 Years Of Operational Guarantee

3 TRACK - 6 SHUTTER

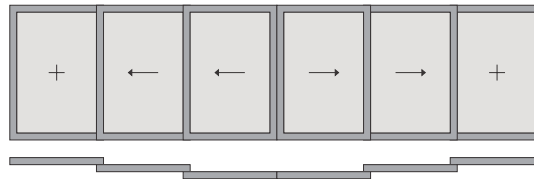

2 TRACK - 3 SHUTTER (X-2X-X)

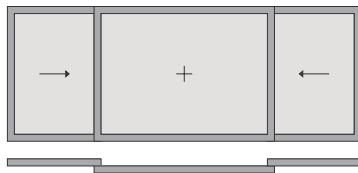

2 TRACK - 4 SHUTTER

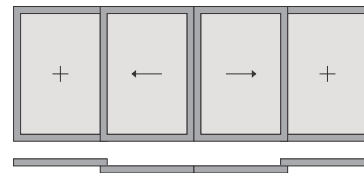

2 TRACK - 2 SHUTTER

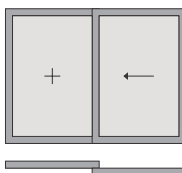

3 TRACK - 3 SHUTTER

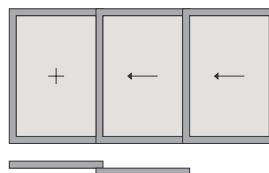

3 TRACK - 4 SHUTTER + 2 MESH SHUTTER

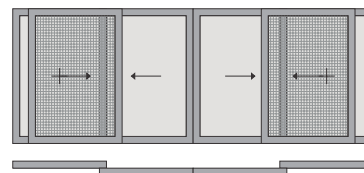

3 TRACK - 2 SHUTTER + 1 MESH SHUTTER

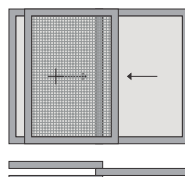

3 TRACK - 3 SHUTTER + 2 MESH SHUTTER

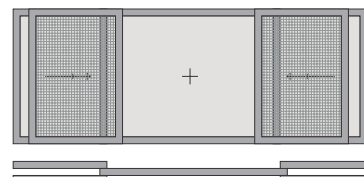

HS3600

SLIDING SYSTEMS

This marvellously designed sleek system is the ideal solution for sliding Along with fix concept which meets highest point of aesthetic performance & functionality. This sleek series having highest standard in terms of elegance, comfort, and performance. The interlock and fix partition profile add a lost of glamour's in this system.

This hybrid system is a complete solution for today's complex construction.

Proper euro groove of locking enhance the security perspective and Ss304 rollers with aluminium body enhance the performance perspective in this system also plastic accessories makes this system complete.

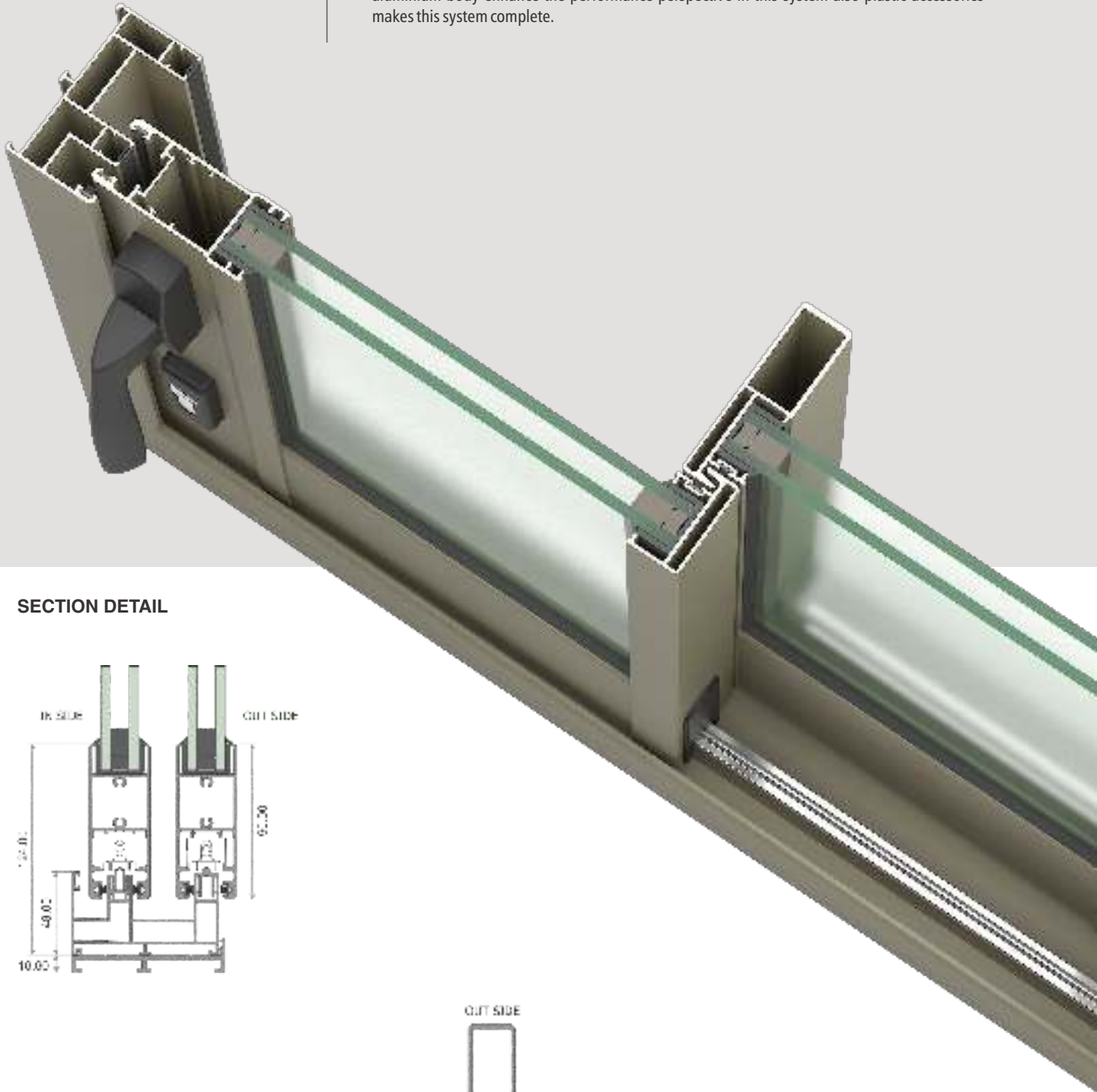

SECTION DETAIL

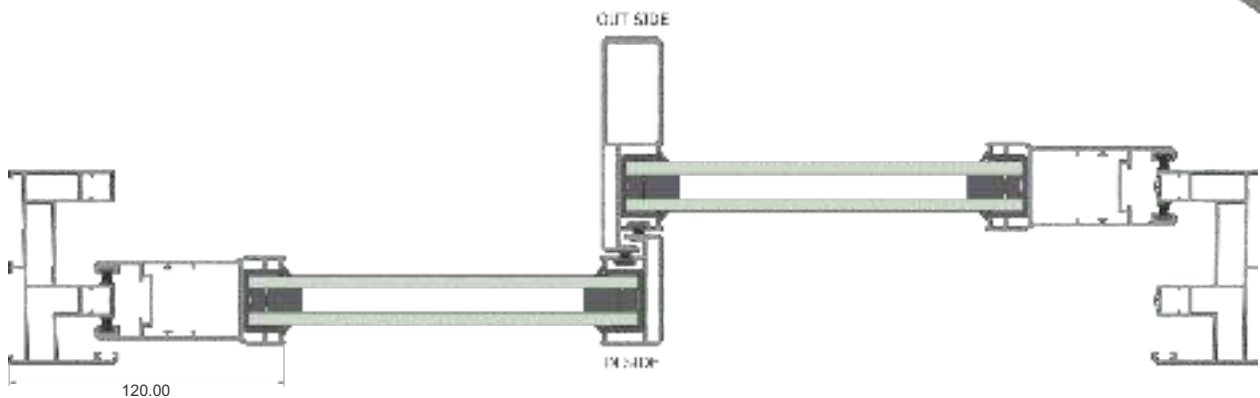
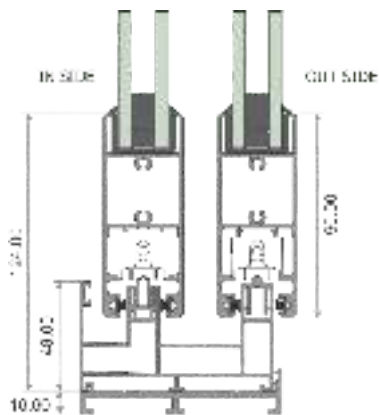

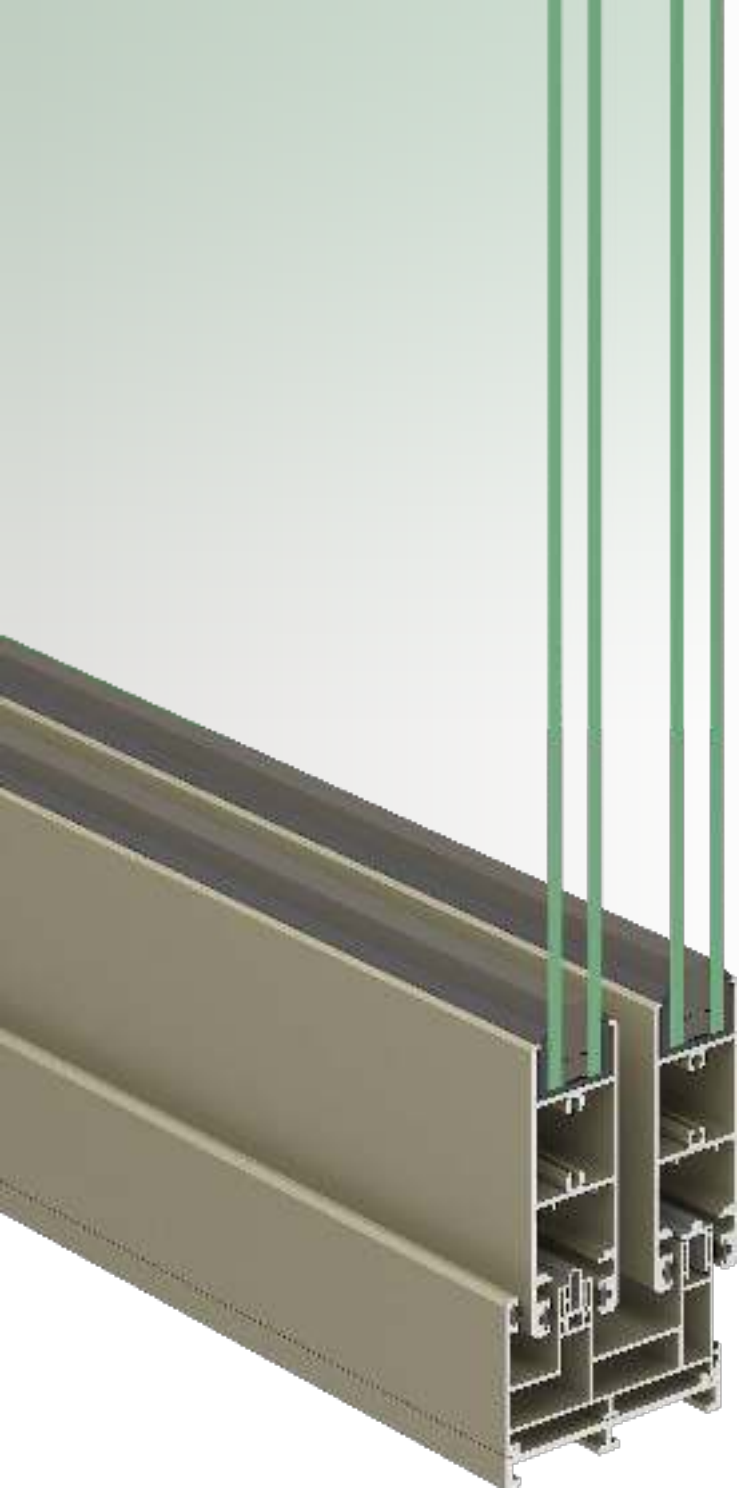

TECHNICAL SPECIFICATION

▶ Frame Height	: 48mm
▶ 3-track Outer Width	: 135mm
▶ 2-track Outer Width	: 85mm
▶ Interlocking Sightline	: 26mm
▶ Roller Capacity	: Upto 200 Kg/pair
▶ Glass Thickness	: 5mm To 26mm
▶ Max Shutter Height	: 3200mm
▶ Security Key Locking Option	: Available
▶ Top & Bottom Fix Option	: Available
▶ Bottom Seal	: Available

WATER DRAINAGE

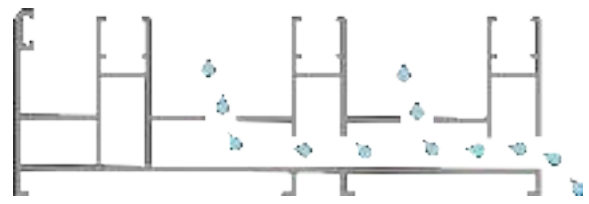

SLIM MEETING PROFILE

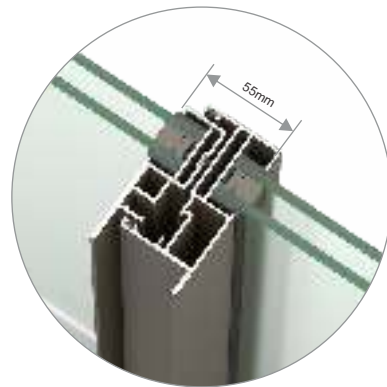

AIR PERMEABILITY	SOUND INSULATION	WATER TIGHTNESS
WIND RESISTANCE	IMPACT RESISTANCE	AIR TIGHTNESS

SYSTEM SPECIFICATION

- Modern Design.
- Design for Bungalows & Project
- Sleeker & Studier.
- Smooth & Effortless During Operation.
- Proper Solution For Today's Complex Construction.
- Combination Of Sliding & Fix Windows.
- Maintenance Free.
- Security Key Locking Option Available For Safety.
- Bottom Sill Available For Protection Of Leakage Issue.
- SS304 U-Groove Bottom Rail For Smooth Sliding.
- Fix & Adjustable Rollers Available.
- SS304 Wheel High Speed Roller Available For Heavy Duty Shutter Up To 200 Kg.
- Provision For Mosquito Mesh.

A L U K I N G

HS3600

SLIDING SYSTEMS

HARDWARE SPECIFICATIONS

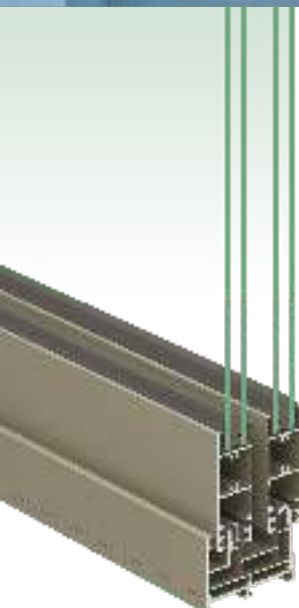

- Wide Range Of Locking Handles.
- Fix & Adjustable Rollers Up To 200 Kg Capacity.
- SS304 Wheel Roller with German Ball Bearing for Smooth Sliding in Heavy Shutter.
- Euro Groove Multi Point Locking System.
- Cylinder key locking for heavy security .
- Customized Plastic Components Like Interlock Cap, Lock Guide, & Buffer Bump Stop Etc.
- Non Return Drainage Solution.
- All Size Of Glass Packers And Frame Packers.
- Microwave Cured EPDM Rubber Gasket For All Glass Size.
- All Hardware Is Having A 10 Years Of Operational Guarantee.

3 TRACK - 6 SHUTTER



2 TRACK - 3 SHUTTER (X-2X-X)

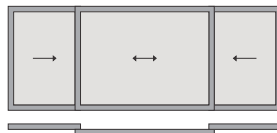

2 TRACK - 4 SHUTTER

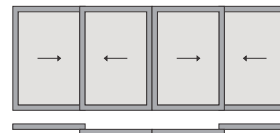

2 TRACK - 2 SHUTTER

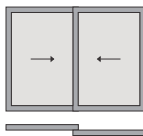

3 TRACK - 3 SHUTTER

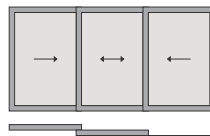

3 TRACK - 4 SHUTTER + 2 MESH SHUTTER



3 TRACK - 2 SHUTTER + 1 MESH SHUTTER

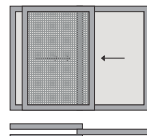

3 TRACK - 3 SHUTTER + 2 MESH SHUTTER

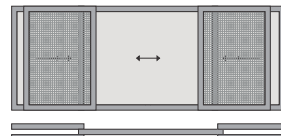

2 TRACK - 4 SHUTTER (CORNER OPENING)

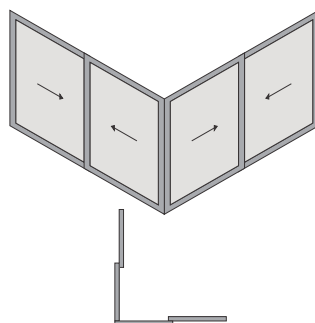

3 TRACK - 6 SHUTTER (CORNER OPENING)

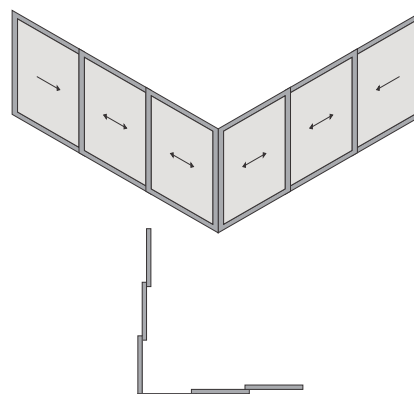

GS3600

SLIDING SYSTEMS

This marvellously designed sleek system is the ideal solution for sliding windows which meets highest point of aesthetic performance & functionality. This sleek series is having highest standard in terms of elegance, comfort, and performance. The slim interlock and slim meeting profile add lots of glamour's in this system.

Narrow sightline, L-corner window solution and slim meeting profile for wide span is makes this system perfect for today's complex construction.

Proper euro groove of locking enhance the security perspective and Ss304 rollers with aluminium body enhance the performance perspective in this system also plastic accessories makes this system complete.

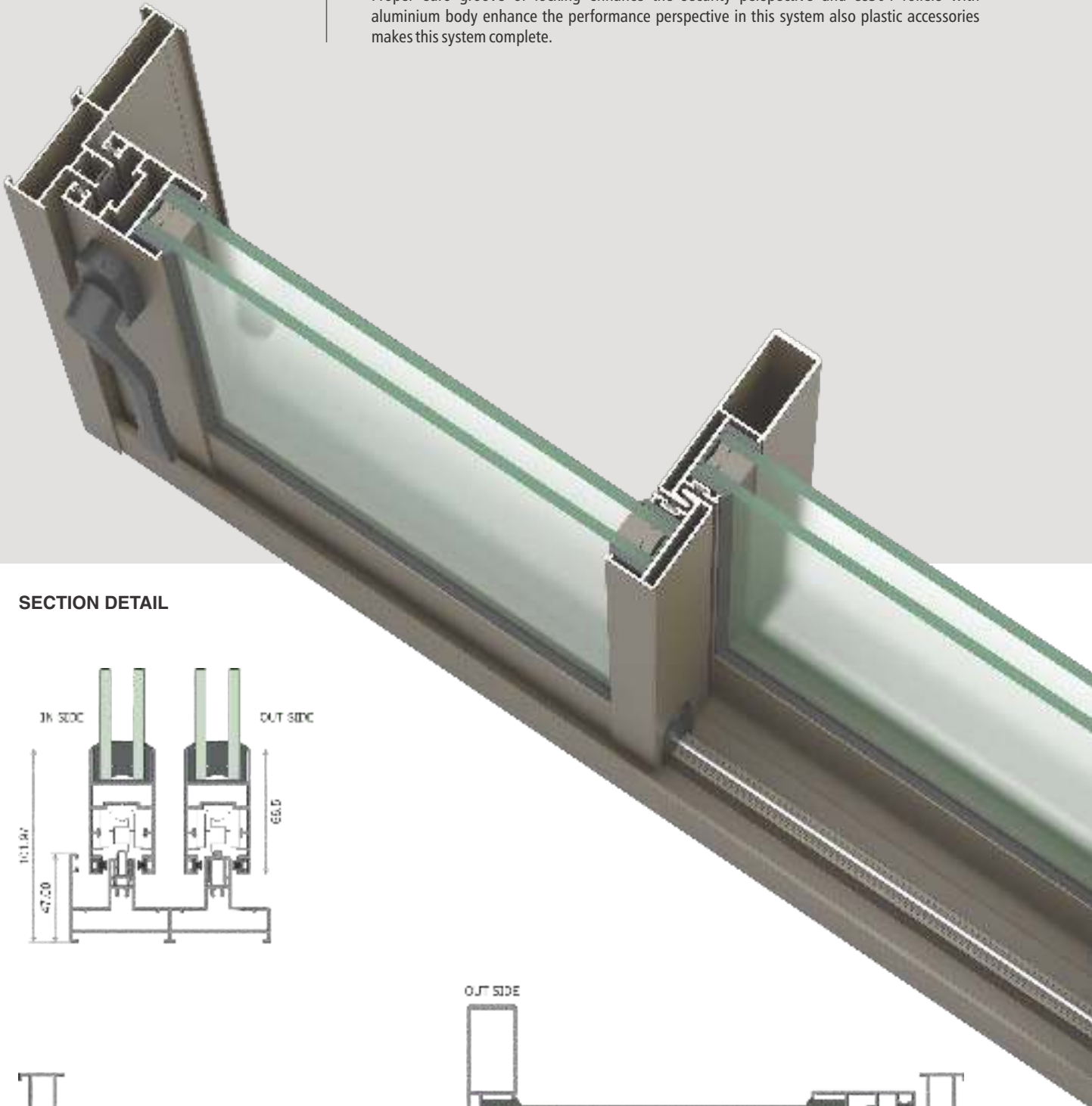

SECTION DETAIL

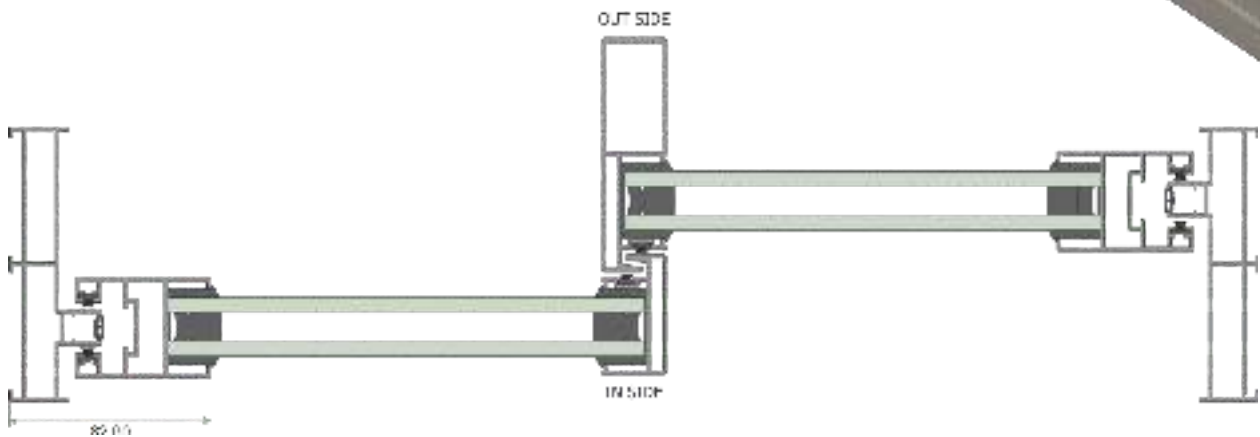
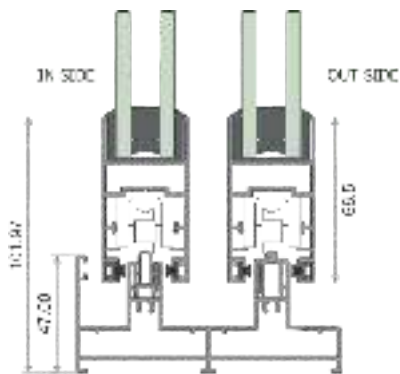

SLIM MEETING PROFILE

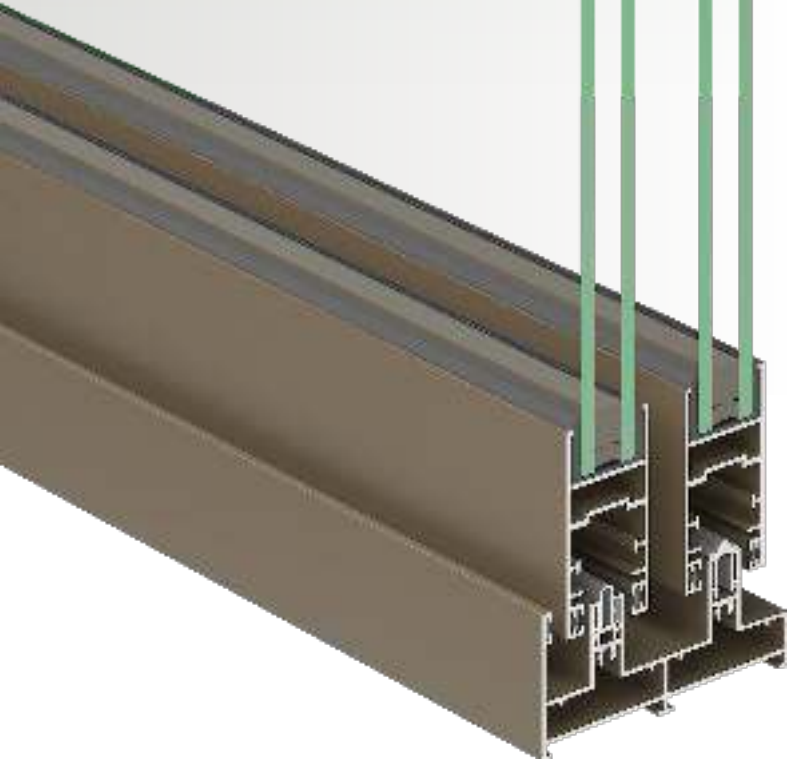
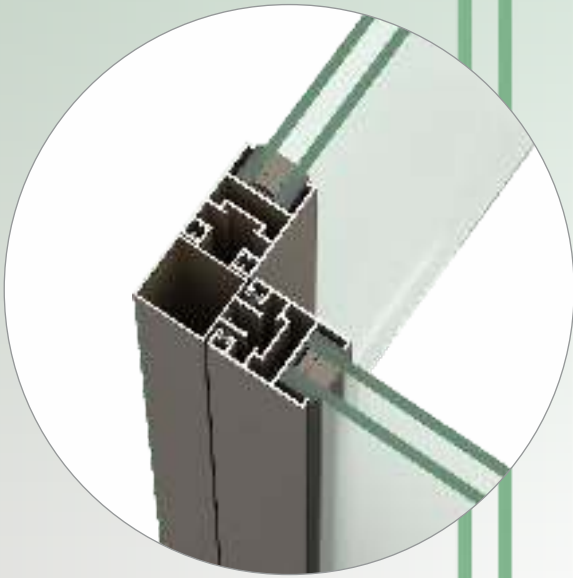

TECHNICAL SPECIFICATION

▶ Frame Height	: 47mm
▶ 3 - Track Frame Width	: 160mm
▶ 2 - Track Frame Width	: 109.5mm
▶ Interlocking Profile Width	: 26mm
▶ Roller Weight Capacity	: Upto 200 Kg/Pair
▶ Glass Thickness	: 5mm To 26mm
▶ Max Shutter Height	: 3200mm
▶ Slim Meeting Option	: Available (55mm)
▶ L-Corner Window	: Available

WATER DRAINAGE

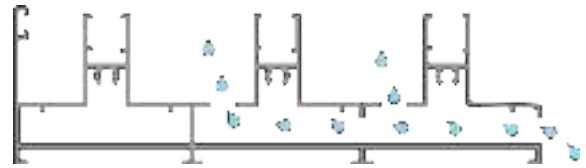

SLIM MEETING PROFILE

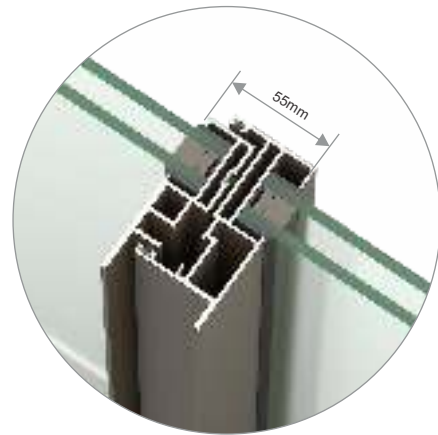

SYSTEM SPECIFICATION

- Flexible Design.
- Design for Bungalows & Project
- Smooth & Effortless During Operation.
- Narrow Sightings With Lateral Sill 80mm Only With 26mm Slimest Interlocking Profile.
- External & Internal Corner Opening Solution.
- Slim Meeting (55mm) Profile To Maintain Slimness Of System In Wide Openings Also.
- Discreet Corner Post.
- Up To 26mm Glass Option Available.
- Single & Multi Point Locking.
- SS304 U-Groove Bottom Rail For Smooth Sliding.
- Reinforcement Interlock Available To Resist Wind Pressure In High Rise.
- Applicable To Buildings With Special Mobility Characteristics.
- Ease Of Use & High Functionality.
- L-Corner Window without Corner Mullion.



AIR PERMEABILITY



SOUND INSULATION



WATER TIGHTNESS



WIND RESISTANCE



IMPACT RESISTANCE



AIR TIGHTNESS

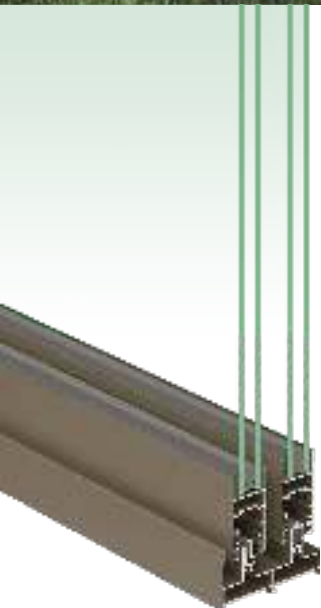

- Wide Range Of Locking Handles.
- Fix & Adjustable Rollers Up To 200 Kg Capacity.
- SS304 Wheel Roller with German Ball Bearing for Smooth Sliding in Heavy Shutter.
- Euro Groove Multi Point Locking System.
- Customized Plastic Components Like Interlock Cap, Lock Guide, & Buffer Bump Stop Etc.
- Non Return Drainage Solution.
- All Size Of Glass Packers And Frame Packers.
- Microwave Cured EPDM Rubber Gasket For All Glass Size.
- All Hardware Is Having A 10 Years Of Operational Guarantee.

3 TRACK - 6 SHUTTER



2 TRACK - 3 SHUTTER (X-2X-X)

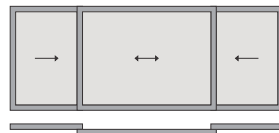

2 TRACK - 4 SHUTTER

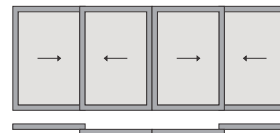

2 TRACK - 2 SHUTTER

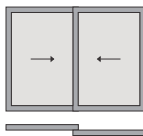

3 TRACK - 3 SHUTTER

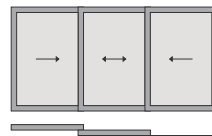

3 TRACK - 4 SHUTTER + 2 MESH SHUTTER



3 TRACK - 2 SHUTTER + 1 MESH SHUTTER

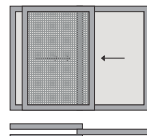

3 TRACK - 3 SHUTTER + 2 MESH SHUTTER

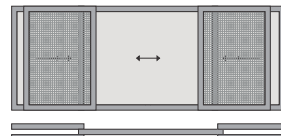

2 TRACK - 4 SHUTTER (CORNER OPENING)

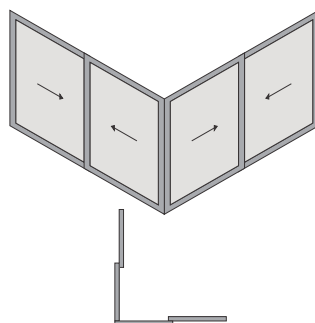

3 TRACK - 6 SHUTTER (CORNER OPENING)

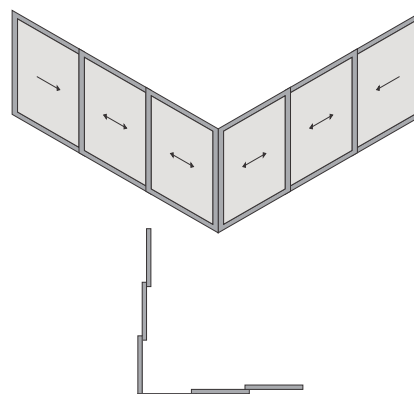

HS4200

SLIDING SYSTEMS

This marvellously designed sleek system is the ideal solution for sliding with fix concept which meets highest point of aesthetic performance & functionality. This sleek series having highest standard in terms of elegance, comfort, and performance. The interlock and fix partition profile add a lot of glamour's in this system.

This system is a complete solution for high rises beside heavy wind load areas.

Proper euro groove of locking enhance the security perspective and Ss304 rollers with aluminium body enhance the performance perspective in this system also plastic accessories makes this system complete.

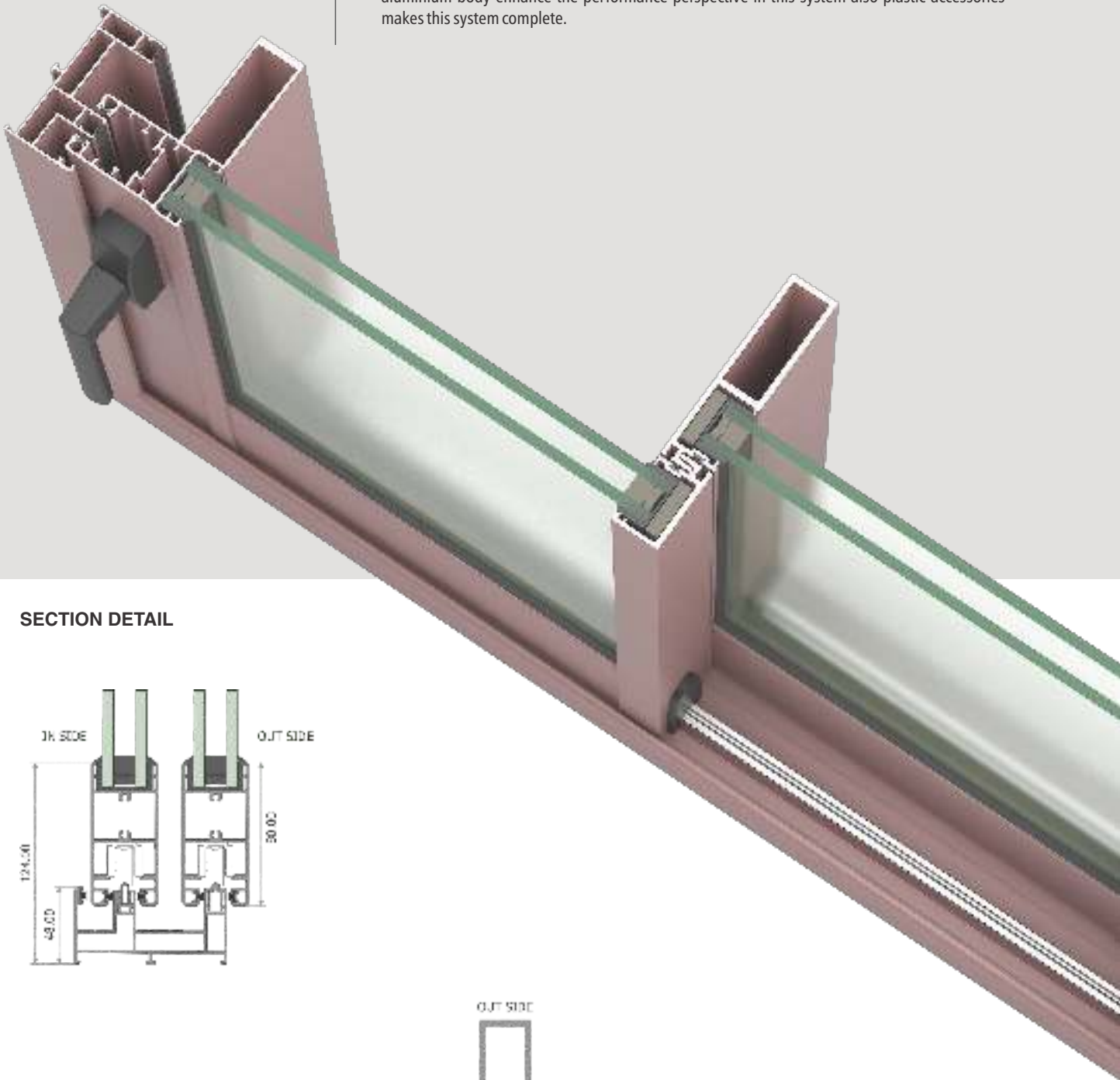

SECTION DETAIL

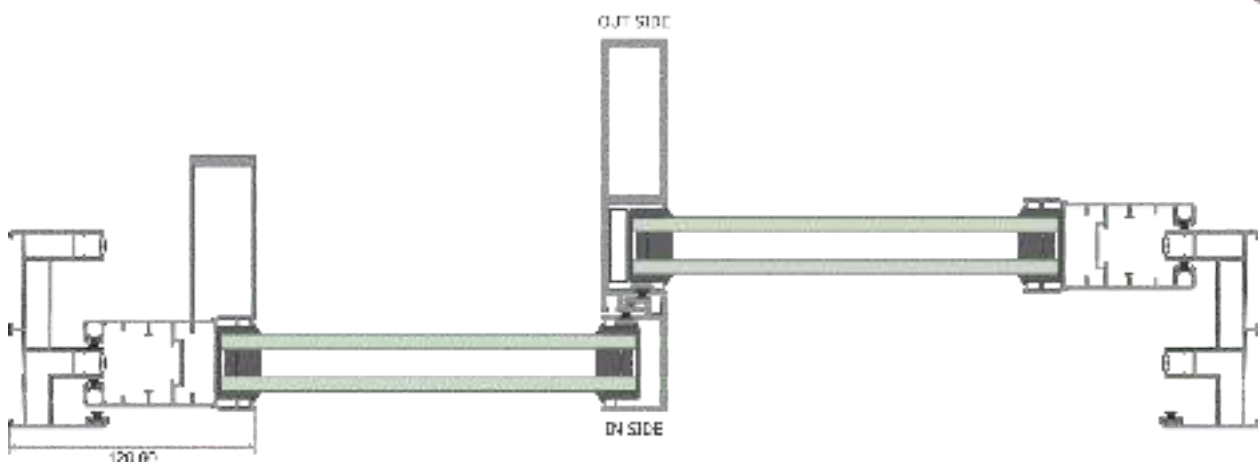
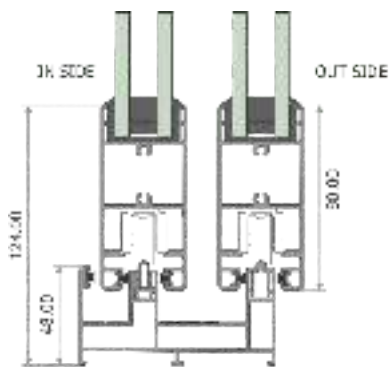

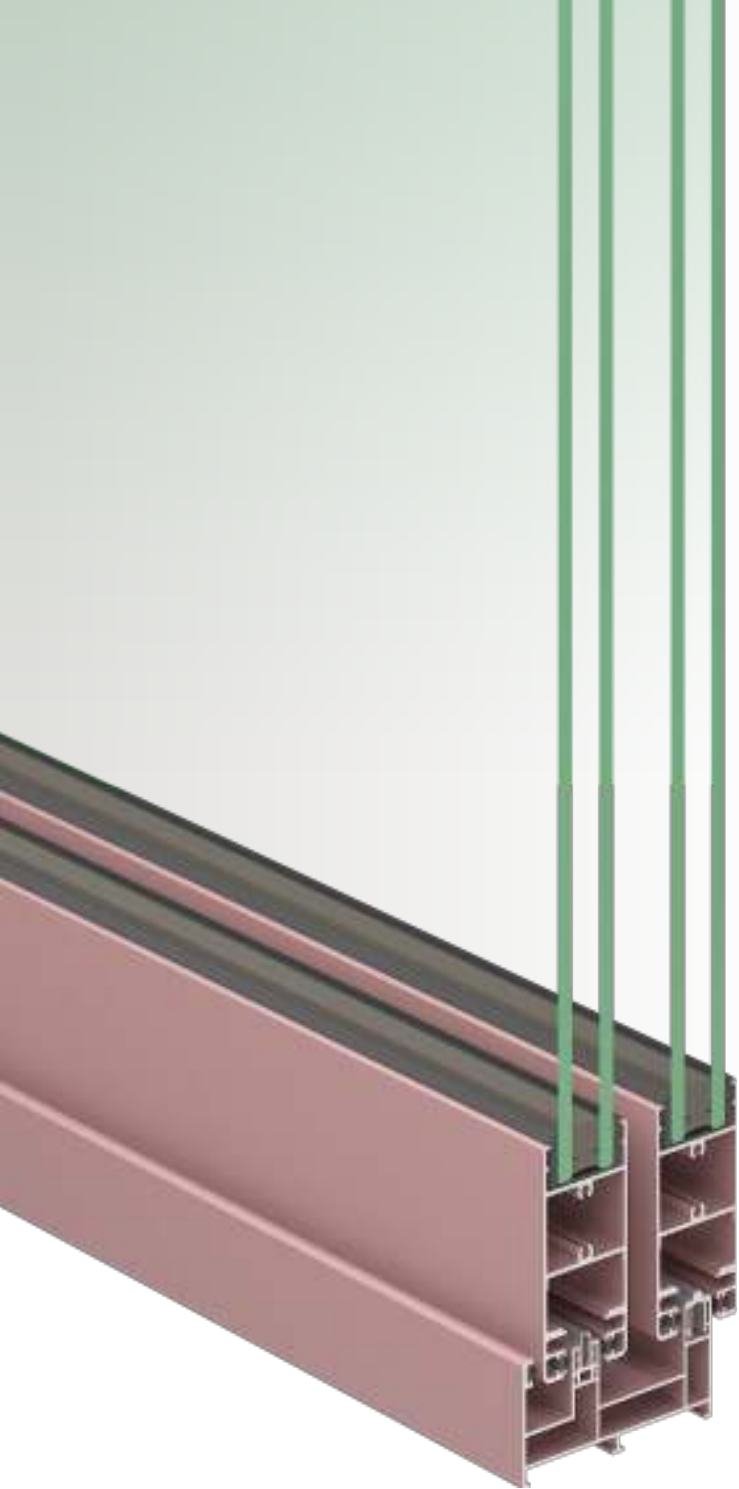

TECHNICAL SPECIFICATION

▶ Frame Height	: 48mm
▶ 3-track Outer Width	: 152.5mm
▶ 2-track Outer Width	: 95.5mm
▶ Interlocking Sightline	: 32mm
▶ Roller Capacity	: Upto 300kg/pair
▶ Glass Thickness	: 24mm To 32mm
▶ Max Shutter Height	: 4200mm
▶ Handle Section With Reinforcement	: Available

WATER DRAINAGE

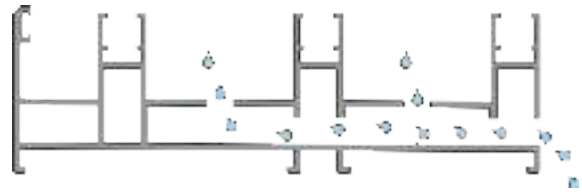

AIR PERMEABILITY



SOUND INSULATION



WATER TIGHTNESS



WIND RESISTANCE



IMPACT RESISTANCE



AIR TIGHTNESS

SYSTEM SPECIFICATION

- Modern Design.
- Design for Bungalows & Project.
- Sleeker & Studier.
- Handle Section With Reinforcement To Stand against Wind Load In High Rises.
- Large Window Openings Up To 4200mm In Height Possible.
- Smooth & Effortless During Operation.
- Multi Point Locking.
- Maintenance Free.
- SS304 U-Groove Bottom Rail For Smooth Sliding.
- Fix & Adjustable Rollers Available.
- SS304 Wheel High Speed Roller Available For Heavy Duty Shutter Up To 300 Kg.
- Provision For Mosquito Mesh.

HARDWARE SPECIFICATIONS

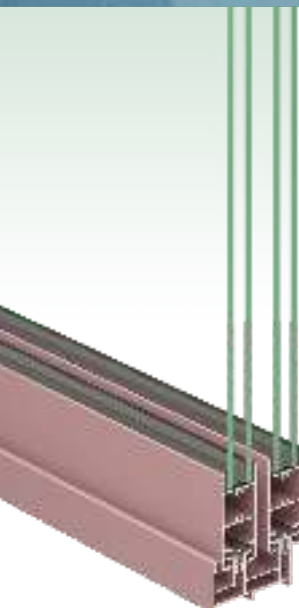

- Wide Range Of Locking Handles.
- Fix Rollers Up To 300 Kg Capacity.
- SS304 Wheel Roller with German Ball Bearing for Smooth Sliding in Heavy Shutter.
- Euro Groove Multi Point Locking System.
- Customized Plastic Components Like Interlock Cap, Lock Guide, & Buffer Bump Stop Etc.
- Non Return Drainage Solution.
- All Size Of Glass Packers And Frame Packers.
- Microwave Cured EPDM Rubber Gasket For All Glass Size.
- All Hardware Is Having A 10 Years Of Operational Guarantee.

3 TRACK - 6 SHUTTER

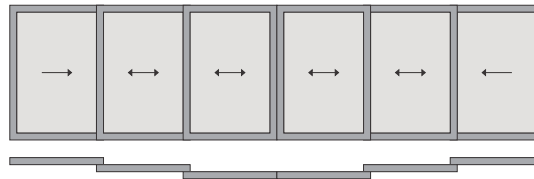

2 TRACK - 3 SHUTTER (X-2X-X)

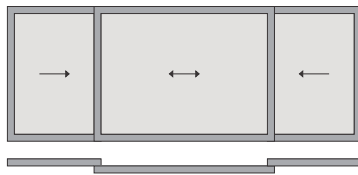

2 TRACK - 4 SHUTTER

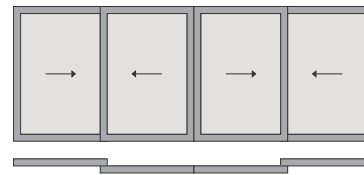

2 TRACK - 2 SHUTTER

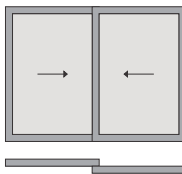

3 TRACK - 3 SHUTTER

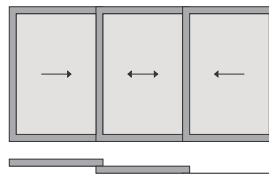

3 TRACK - 4 SHUTTER + 2 MESH SHUTTER

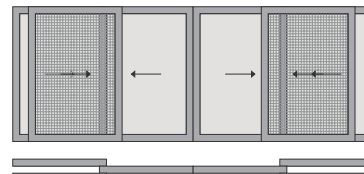

3 TRACK - 2 SHUTTER + 1 MESH SHUTTER

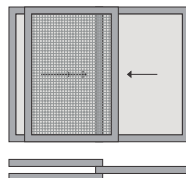

3 TRACK - 3 SHUTTER + 2 MESH SHUTTER

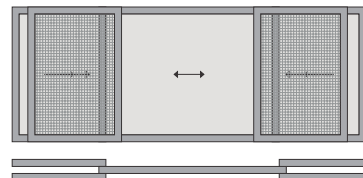

H300

SLIDING SYSTEMS

This Marvellous Designed Slim Series Is A Ideal Solution For Sliding Door Which Require Esthetic Performance & Functionality. This Slim Series Is Elaborated To Meet Highest Standards Of Elegance, Comfort, And Performance. The Interlocking Profile Add A Lot Of Glamour To This Window System.

This Series Made For High Performance, Aluminium Can Endure Heavy Loads & Ensures Safety Even When Subjected To Severe Weather Condition .

This High Resisting Contrives Makes It The Ideal Choice For Sliding Doors Required For High Rise Residential Buildings and lavish apartments.



Scan QR For Quality Tasted Certificate

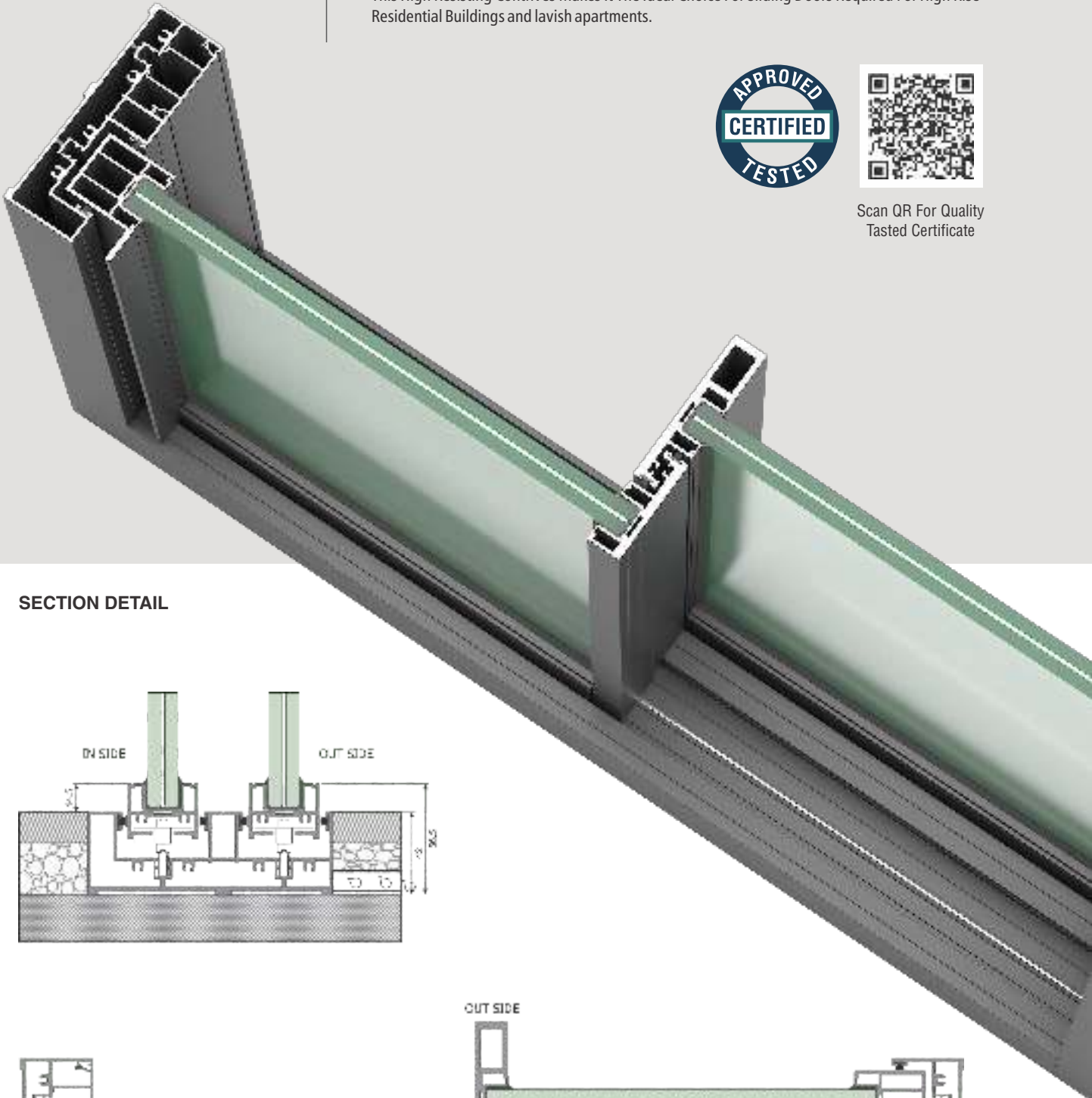

SECTION DETAIL

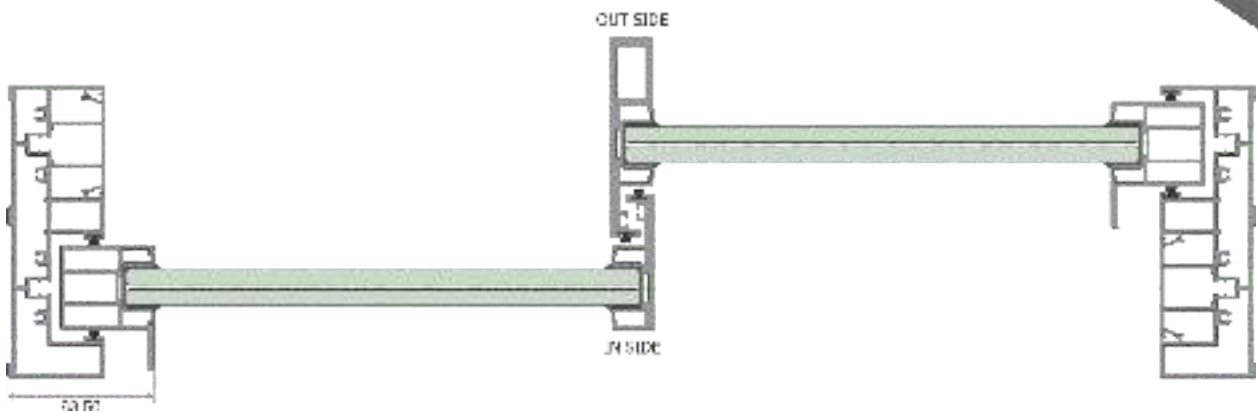
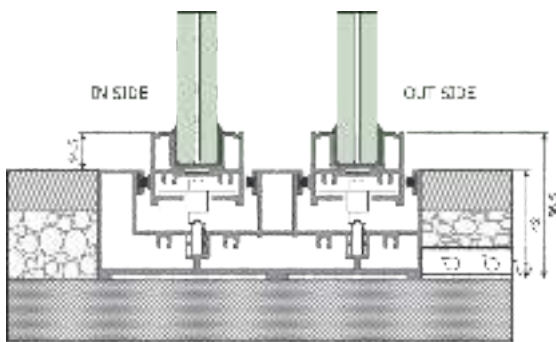

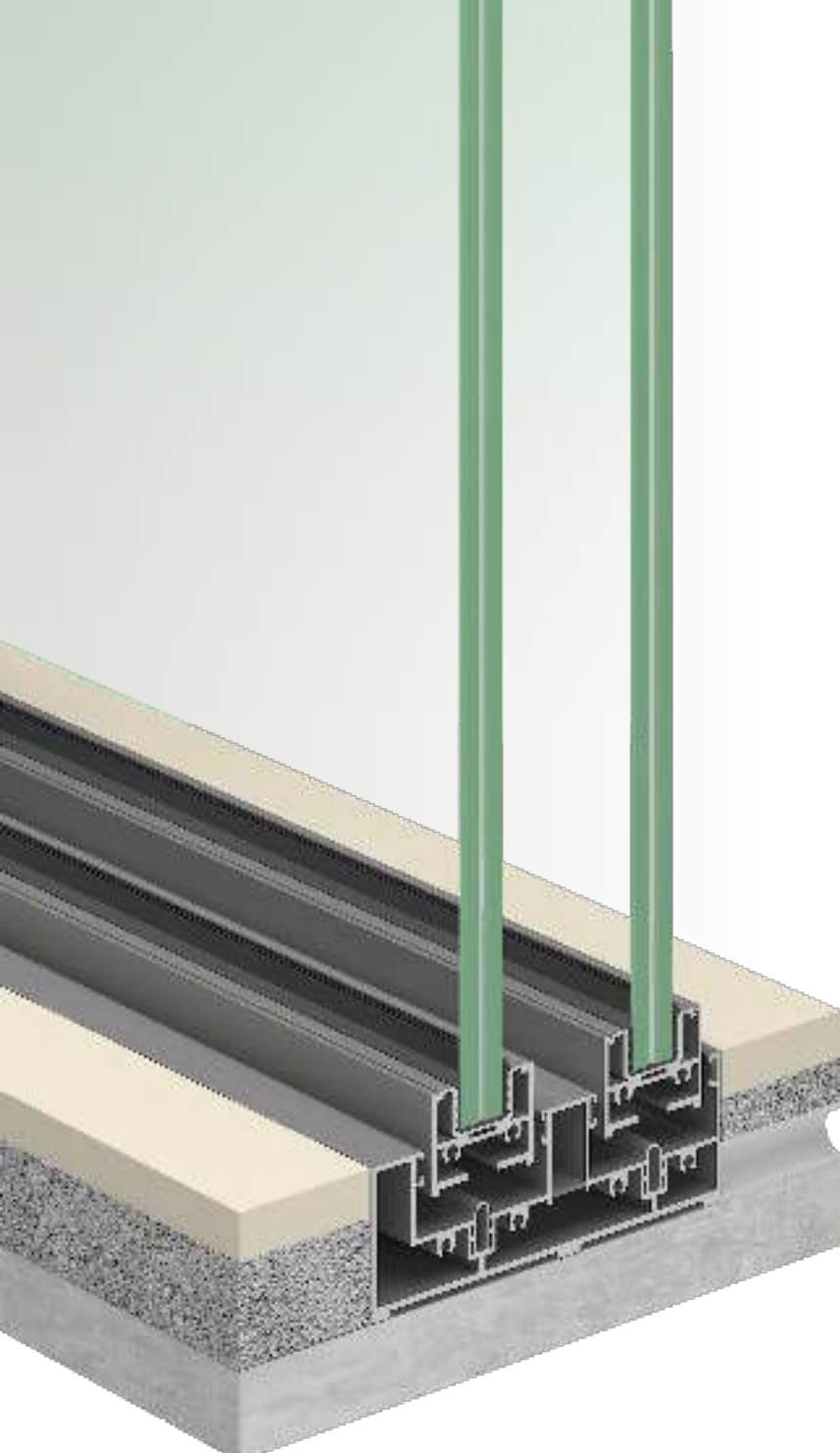

TECHNICAL SPECIFICATION

▶ Outer Frame Height	: 42mm
▶ 3 Track Outer Width	: 187.7mm
▶ 2 Track Outer Width	: 125mm
▶ Interlocking Sightline	: 18mm
▶ Roller Capacity	: Upto 350kg/pair
▶ Glass Thickness	: 5mm To 26mm
▶ Max Shutter Height	: 3000mm
▶ Slim Meeting Section	: Available
▶ Floor Conceal Option	: Available
▶ Railing Option	: Available

WATER DRAINAGE

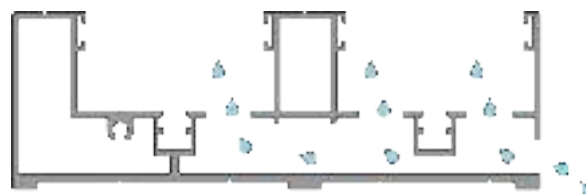

SYSTEM SPECIFICATION

- Minimalist Design.
- Design for Bungalows & Project.
- Sleeker & Studier.
- A Frame less Aspect By Concealed Outer Frame In Building's Construction.
- Extremely Slim Interlocking Profile (18mm) That Gives An Uninterrupted View.
- Enhanced Natural Light Thank's To System's Minimal Design & Wide Glazing Options.
- Exceptional Sound Insulation.
- SS304 U-Groove Bottom Rail For Smooth Sliding.
- Increased Static Load & Functionality In Case Of Severe Weather Condition.
- Up To 26mm Glass Option Available.
- Reinforcement Interlock Available To Resist Wind Pressure In High Rise.
- SS304 Wheel High Speed Roller Available For Heavy Duty Shutter Up To 350 Kg.



AIR PERMEABILITY



SOUND INSULATION



WATER TIGHTNESS



WIND RESISTANCE



IMPACT RESISTANCE



AIR TIGHTNESS

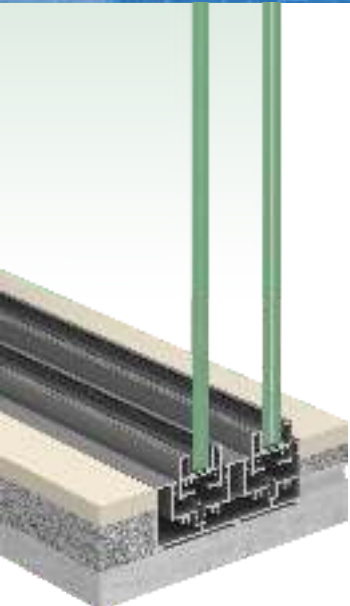

- Fix Rollers Up To 350 Kg Capacity (Expand up to 500 Kg)
- SS304 Wheel Roller with German Ball Bearing for Smooth Sliding in Heavy Shutter.
- Top & Bottom locking mechanism
- Customized Plastic Components Like handle adapter, frame joint adapter, shootbolt guide etc.
- Non Return Drainage Solution.
- All Size Of Glass Packers And Frame Packers.
- Microwave Cured EPDM Rubber Gasket For All Glass Size.
- All Hardware Is Having A 10 Years Of Operational Guarantee.

3 TRACK - 6 SHUTTER

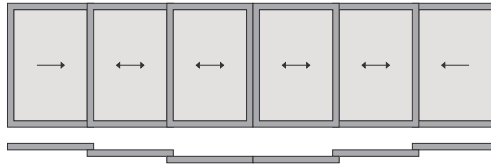

2 TRACK - 3 SHUTTER (X-2X-X)

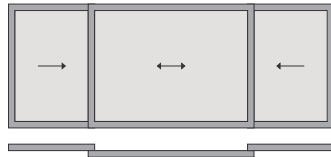

2 TRACK - 4 SHUTTER

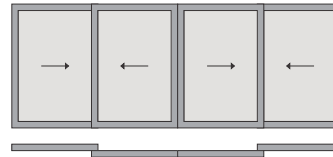

2 TRACK - 2 SHUTTER

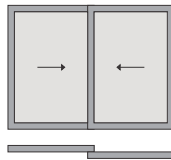

3 TRACK - 3 SHUTTER

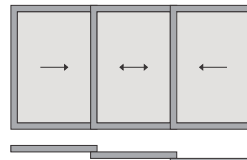

2 TRACK - 4 SHUTTER (CORNER OPENING)

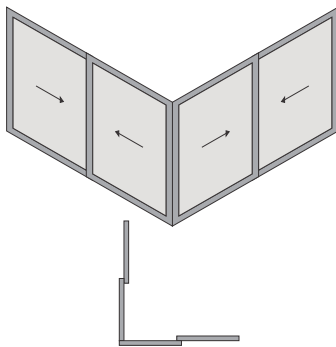

3 TRACK - 6 SHUTTER (CORNER OPENING)

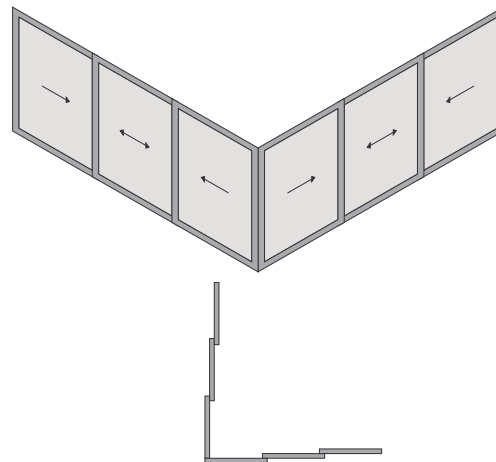

H360

SLIDING SYSTEMS

Aluking Minimal System Are Groundbreaking Design. / Original Solutions For Large And Impressive Constructions. / High Energy Efficiency And Top Performance.

Minimal Sliding System Are ideal solution for projects requiring wide spans with minimal aluminium site lines Minimal System main advantage is the improvement of living conditions, by maximizing the natural light and minimizing the visible aluminium face width. Thus, the residents feel closer to the external environment, increasing their sense of freedom Minimal System maintaining high functionality With Stainless steel rollers for smooth sliding and maximum functionality, with high resistance to corrosion

Minimal system the best choice for the most demanding projects in the most advanced markets.

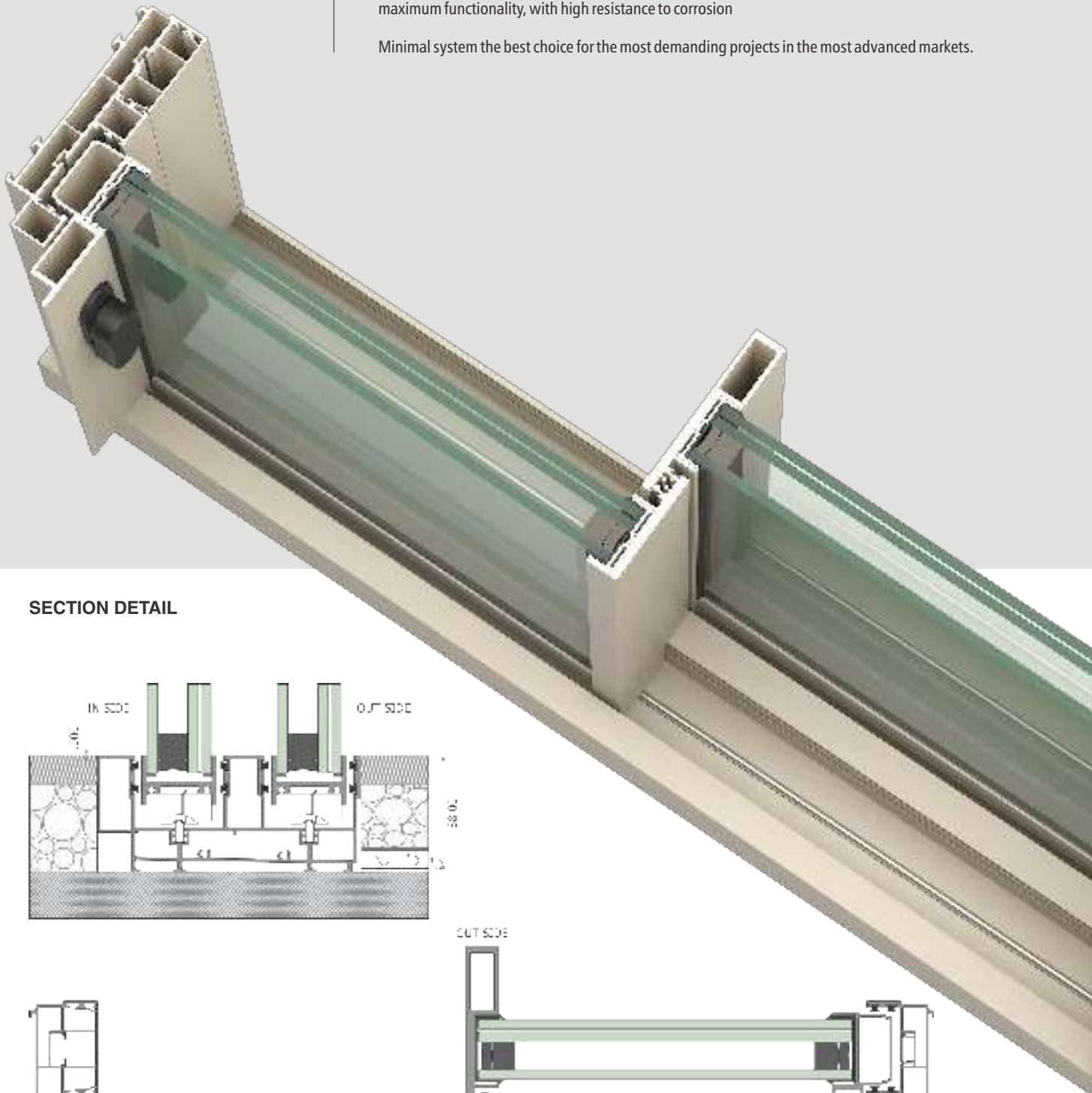

SECTION DETAIL

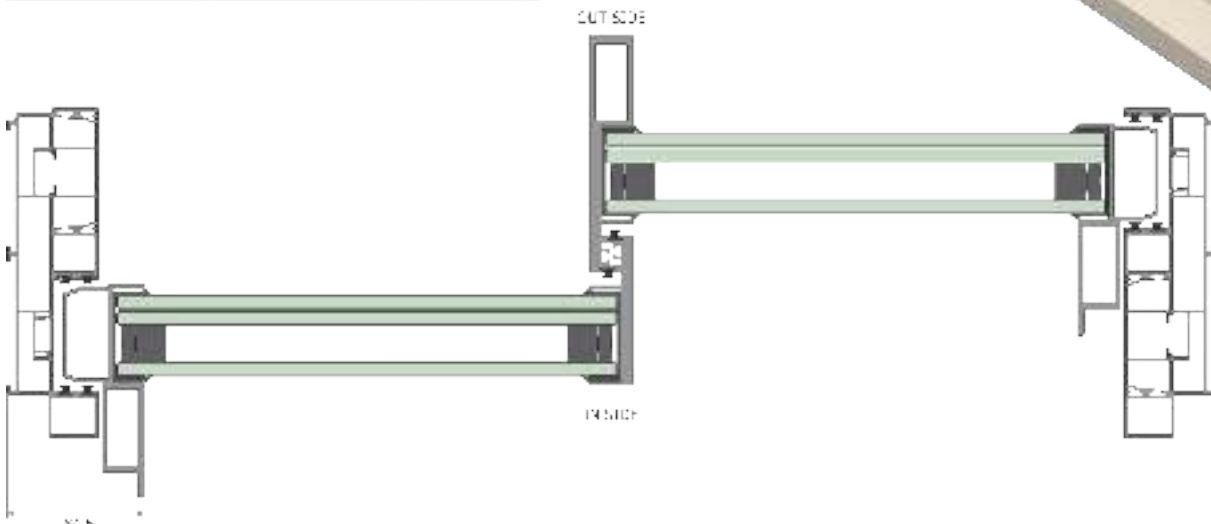
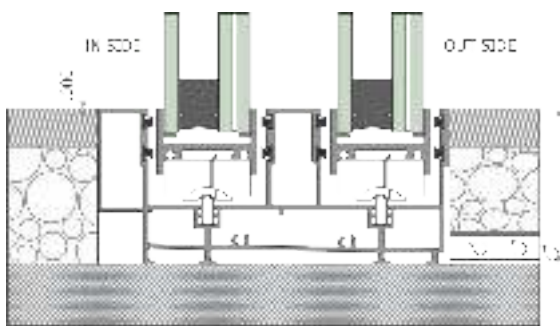

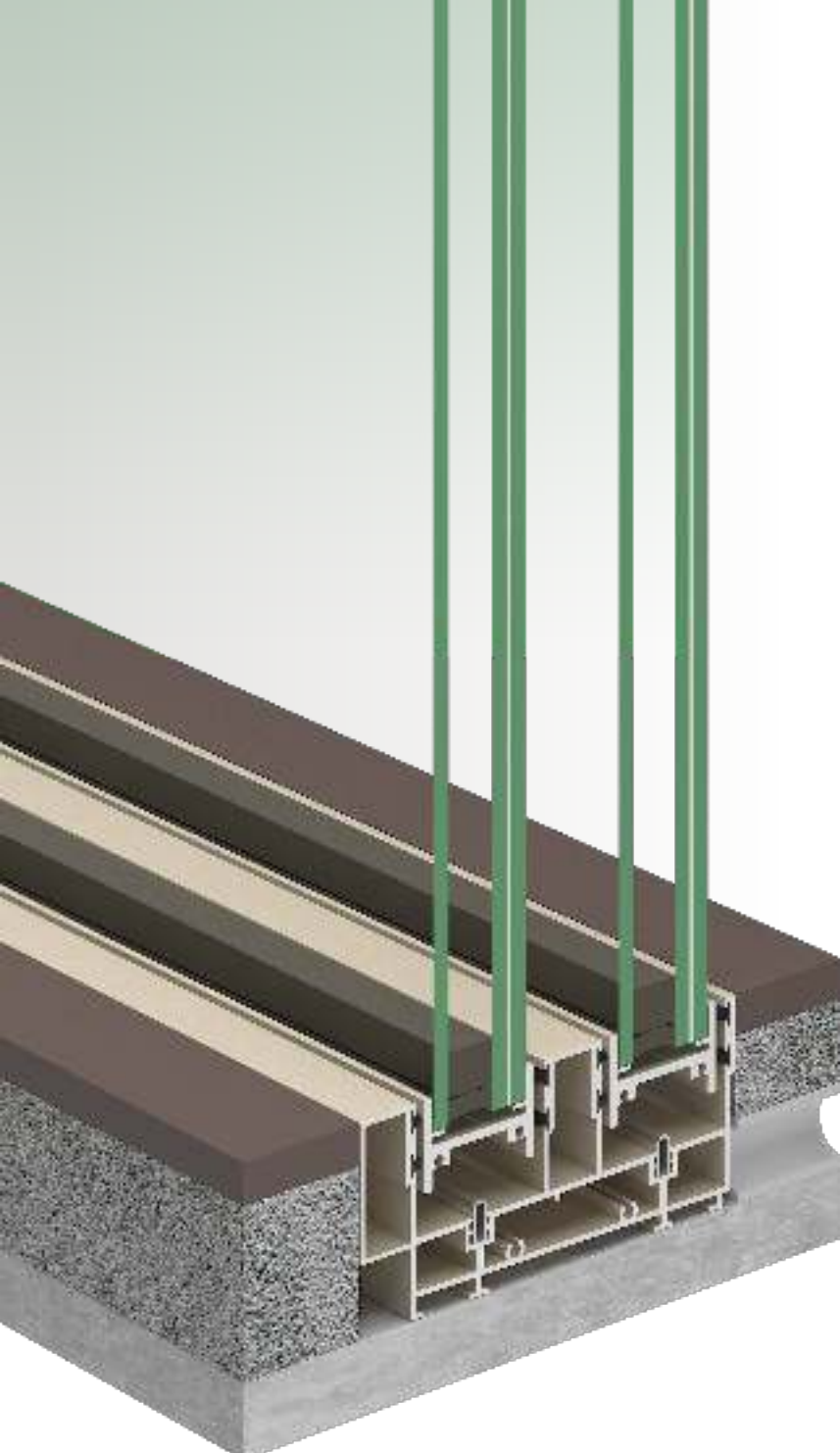

TECHNICAL SPECIFICATION

▶ Outer Frame Height	: 68mm
▶ 2 Track Outer Width	: 155mm
▶ Interlocking Sightline	: 20mm
▶ Roller Capacity	: Upto 500kg/pair
▶ Glass Thickness	: 8mm to 36mm
▶ Max Shutter Height	: 5000mm
▶ Slim Meeting Section	: Available
▶ Floor Consile Option	: Available
▶ L-corner Option	: Available

WATER DRAINAGE



SYSTEM SPECIFICATION

- Minimalist Design.
- Design for Bungalows & Project.
- Sleeker & Studier.
- External & Internal Corner Opening Solution.
- Discreet Corner Post.
- A Frame less Aspect By Concealing Outer Frame In Construction.
- Extremely Slim Interlocking Profile (20mm) That Gives An Uninterrupted View.
- Enhanced Natural Light Thanks To System's Minimal Design.
- Large Window Opening Up To 4500 mm In Height Possible.
- SS304 U-Groove Bottom Rail For Smooth Sliding.
- Increased Static Load & Functionality In Case Of Severe Weather Condition. 8mm to 36mm Glass Option Available.
- SS304 Wheel High Speed Roller Available For Heavy Duty Shutter Up To 500 Kg.



AIR PERMEABILITY



SOUND INSULATION



WATER TIGHTNESS



WIND RESISTANCE



IMPACT RESISTANCE



AIR TIGHTNESS

H360

SLIDING SYSTEMS

Aluking Minimal System Are Groundbreaking Design. / Original Solutions For Large And Impressive Constructions. / High Energy Efficiency And Top Performance.

Minimal Sliding System Are ideal solution for projects requiring wide spans with minimal aluminium site lines Minimal System main advantage is the improvement of living conditions, by maximizing the natural light and minimizing the visible aluminium face width. Thus, the residents feel closer to the external environment, increasing their sense of freedom Minimal System maintaining high functionality With Stainless steel rollers for smooth sliding and maximum functionality, with high resistance to corrosion

Minimal system the best choice for the most demanding projects in the most advanced markets.

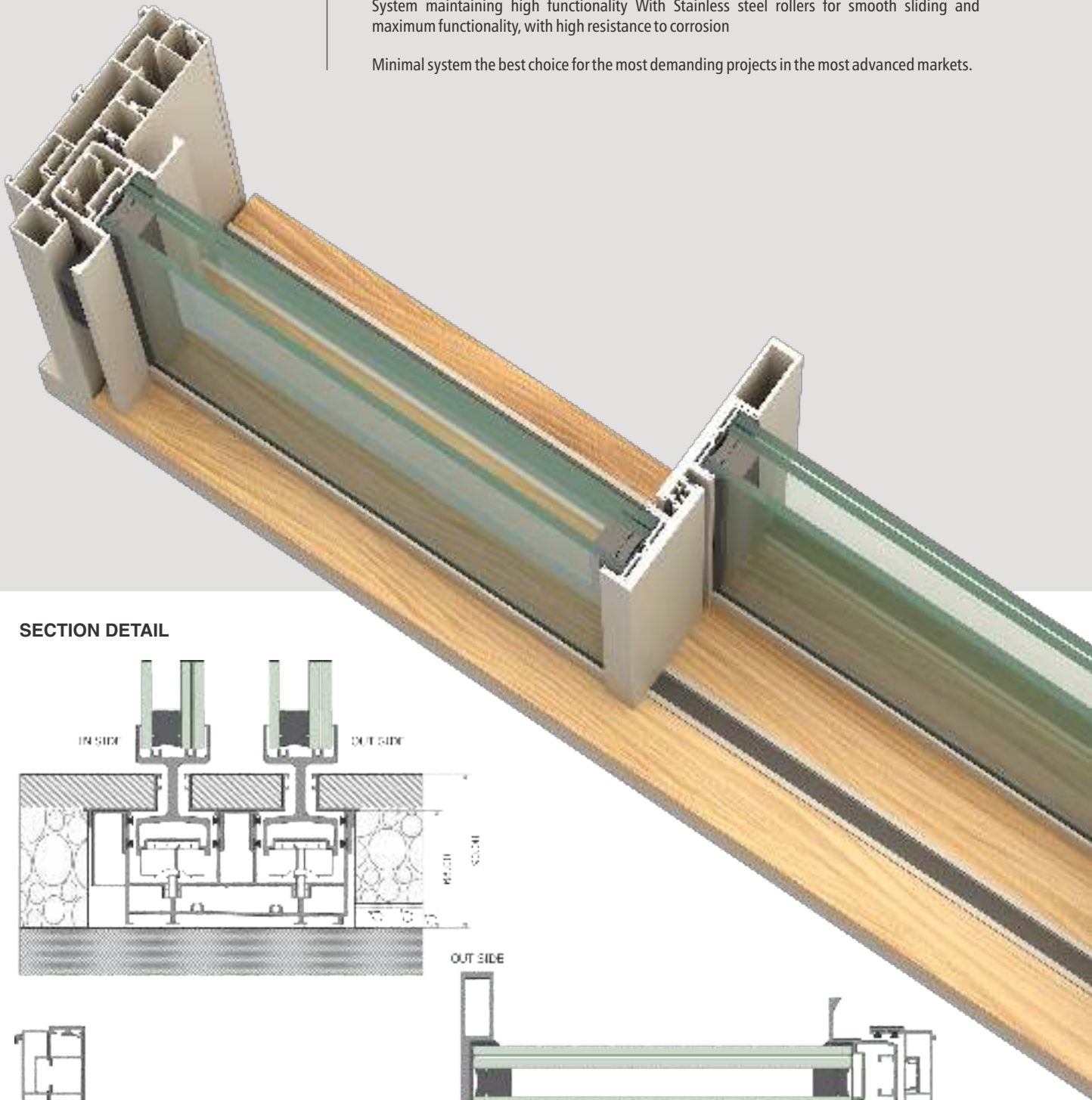

SECTION DETAIL

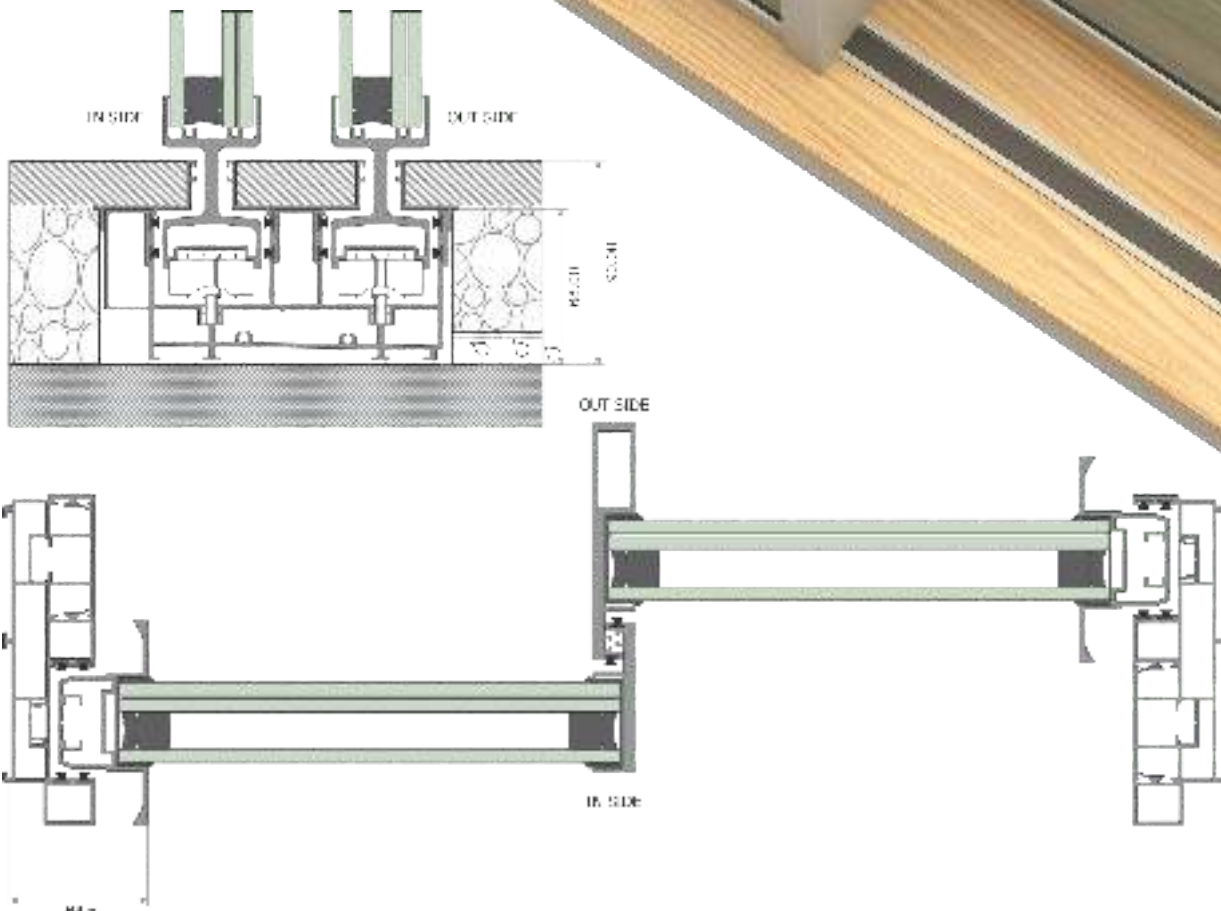

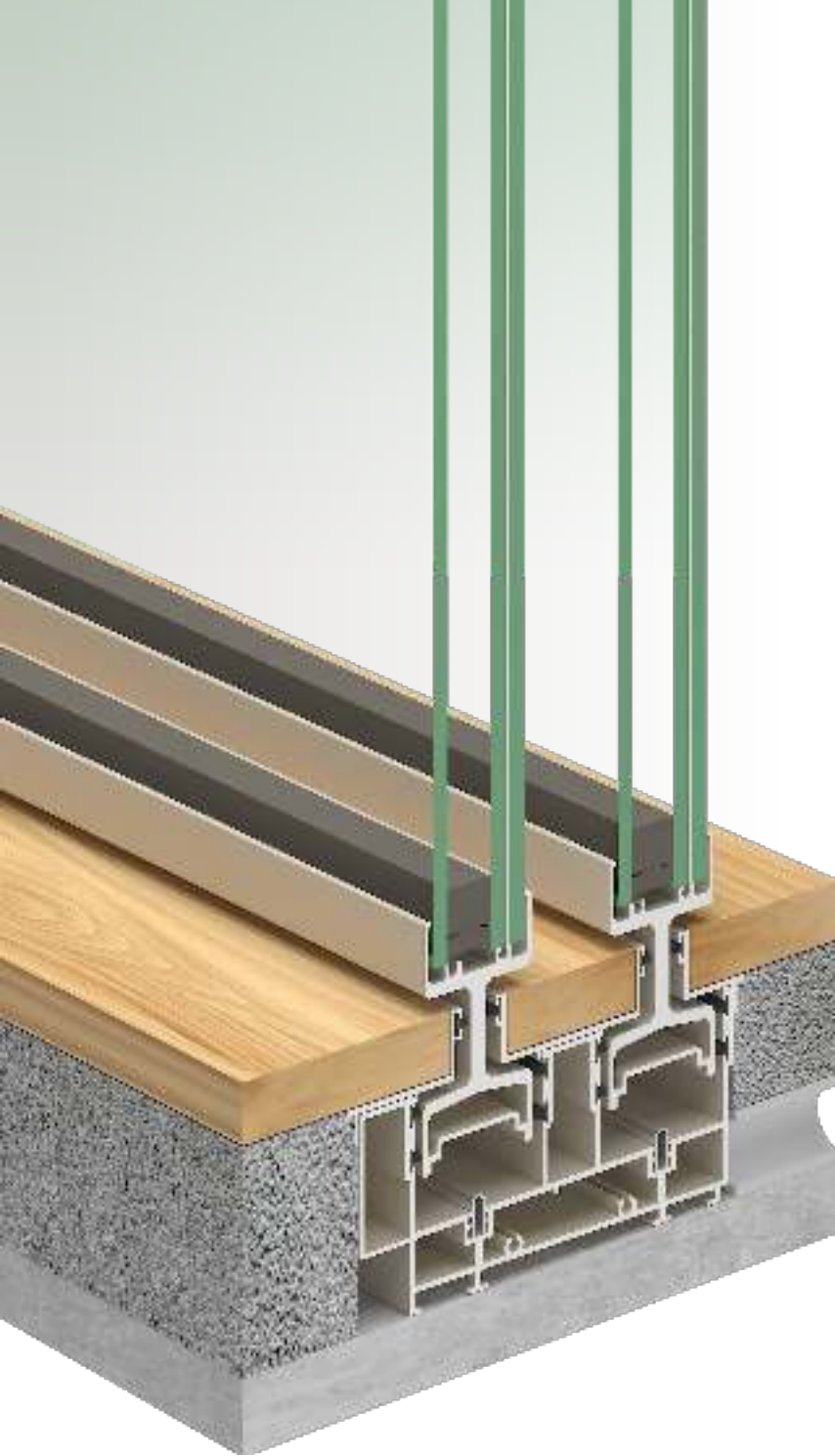

TECHNICAL SPECIFICATION

▶ Outer Frame Deep From Floor	: 90mm
▶ 2 Track Outer Width	: 170mm
▶ Interlocking Sightline	: 20mm
▶ Roller Capacity	: Upto 500kg/pair
▶ Glass Thickness	: 8mm to 36mm
▶ Max Shutter Height	: 5000mm
▶ Slim Meeting Section	: Available
▶ Floor Conceal Option	: Available
▶ L-corner Option	: Available

WATER DRAINAGE



SYSTEM SPECIFICATION

- Minimalist Design.
- Design for Bungalows & Project.
- Perfect Solution for inside partition & wheel chair Access Aspect.
- Sleeker & Studier.
- External & Internal Corner Opening Solution.
- Discreet Corner Post.
- A Frame less Aspect By Concealing Outer Frame In Construction.
- Extremely Slim Interlocking Profile (20mm) That Gives An Uninterrupted View.
- Enhanced Natural Light Thanks To System's Minimal Design.
- Large Window Opening Up To 5000mm In Height Possible.
- SS304 U-Groove Bottom Rail For Smooth Sliding.
- Solid SS Track Support Available for Heavy Shutter.
- Increased Static Load & Functionality In Case Of Severe Weather Condition.



AIR PERMEABILITY



SOUND INSULATION



WATER TIGHTNESS



WIND RESISTANCE



IMPACT RESISTANCE



AIR TIGHTNESS

HARDWARE SPECIFICATIONS

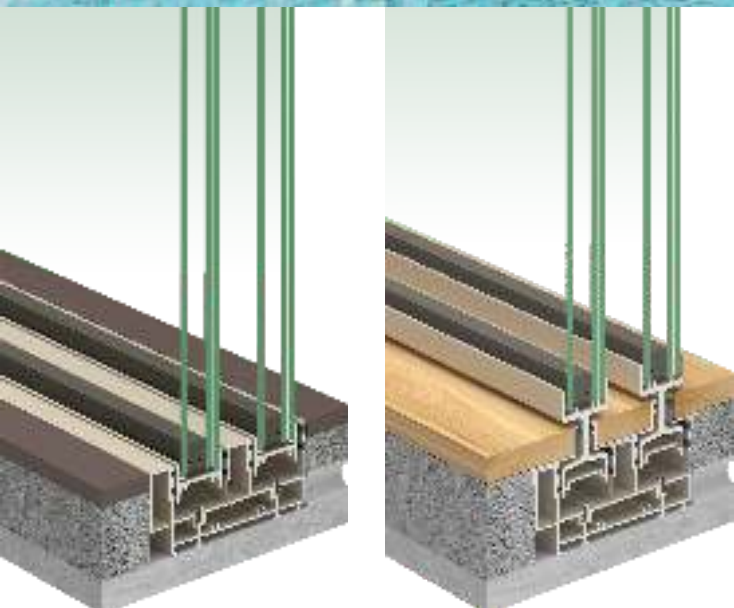

- Fix Rollers Up To 500 Kg Capacity.
- SS304 Wheel Roller with German Ball Bearing for Smooth Sliding in Heavy Shutter.
- Top & Bottom locking mechanism
- Customized Plastic Components Like handle adapter, frame joint adapter, shootbolt guide etc.
- Non Return Drainage Solution.
- All Size Of Glass Packers And Frame Packers.
- Microwave Cured EPDM Rubber Gasket For All Glass Size.
- All Hardware Is Having A 10 Years Of Operational Guarantee.

3 TRACK - 6 SHUTTER

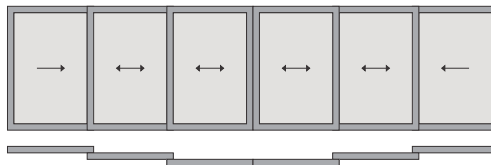

2 TRACK - 3 SHUTTER (X-2X-X)

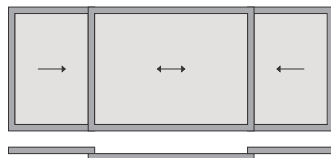

2 TRACK - 4 SHUTTER

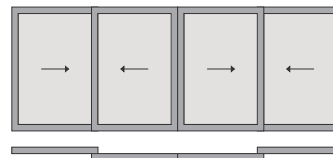

2 TRACK - 2 SHUTTER

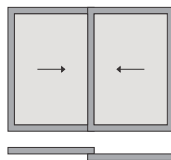

3 TRACK - 3 SHUTTER

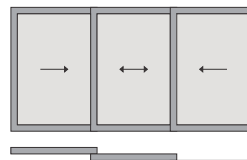

2 TRACK - 4 SHUTTER (CORNER OPENING)

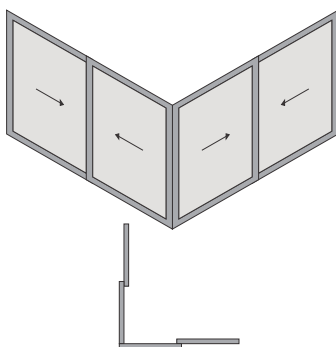

3 TRACK - 6 SHUTTER (CORNER OPENING)

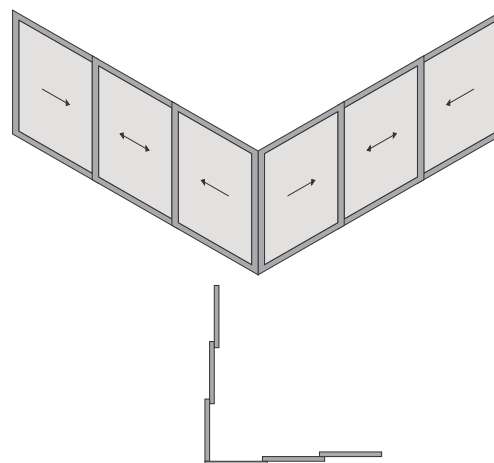

H400

SLIDING SYSTEMS

Experience the perfect blend of form and function with Aluking's H-400 aluminum windows. Boasting a unique inbuilt railing system and a slim, sophisticated design, the H-400 is crafted for those who value modern aesthetics without compromising on durability. It's Heavy weight structure ensures easy installation, making it an ideal choice for contemporary spaces.

The H-400 from Aluking is the latest in high-performance aluminum windows. Featuring an advanced inbuilt railing system and a minimalist, slim profile, the H-400 brings style and innovation together.

Minimal system the best choice for the most demanding projects in the most advanced markets.

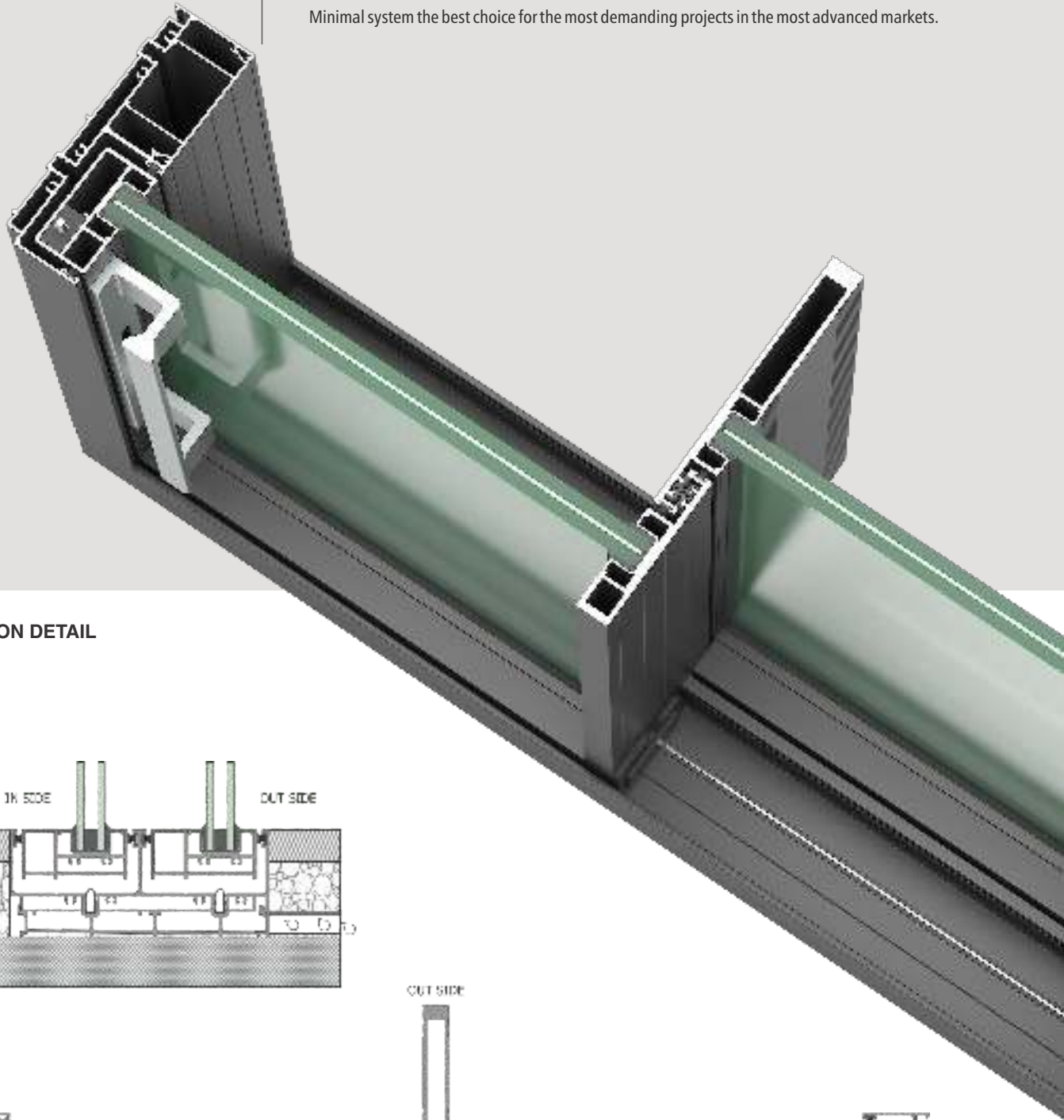

SECTION DETAIL

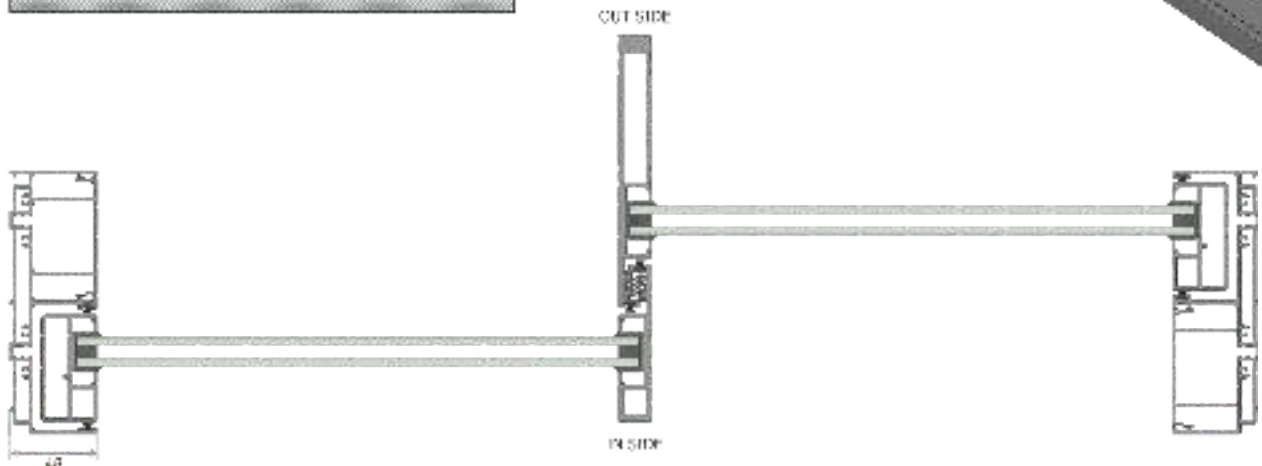
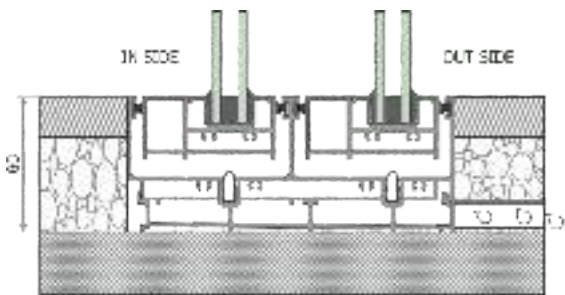

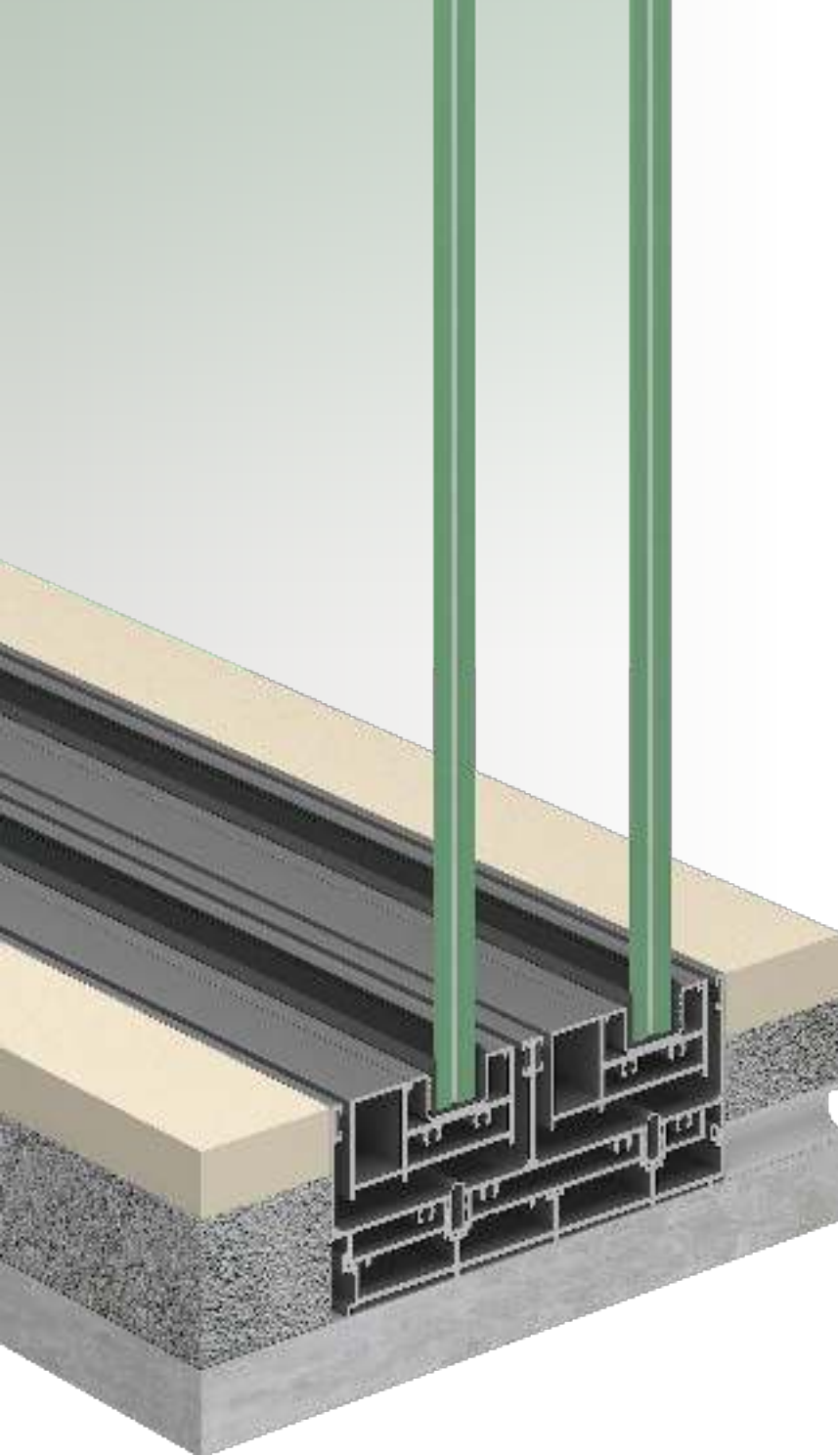

TECHNICAL SPECIFICATION

▶ Frame Height	: 48mm
▶ Bottom Cill Height	: 12mm
▶ 3-track Outer Width	: 217mm
▶ 2-track Outer Width	: 145mm
▶ Interlocking Sightline	: 18mm
▶ Roller Capacity	: Up to 500Kg/Pair
▶ Glass Thickness	: 12 to 32mm
▶ Max Shutter Height	: 4500mm
▶ Slim Meeting Section	: Available
▶ Floor Conceal Option	: Available
▶ L - Corner Option	: Available
▶ Railing Option	: Available

WATER DRAINAGE

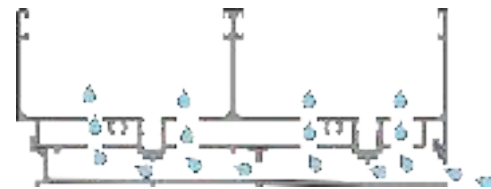

SYSTEM SPECIFICATION

- Minimalist Design.
- Design for Bungalows & Project.
- Sleeker & Studier.
- External & Internal Corner Opening Solution.
- Discreet Corner Post.
- A Frame less Aspect By Concealing Outer Frame In Construction.
- Extremely Slim Interlocking Profile (18mm) That Gives An Uninterrupted View.
- Enhanced Natural Light Thanks To System's Minimal Design.
- Large Window Opening Up To 4500 mm In Height Possible.
- SS304 U-Groove Bottom Rail For Smooth Sliding.
- Increased Static Load & Functionality In Case Of Severe Weather Condition. 12mm to 32mm Glass Option Available.
- SS304 Wheel High Speed Roller Available For Heavy Duty Shutter Up To 500 Kg.



AIR PERMEABILITY



SOUND INSULATION



WATER TIGHTNESS



WIND RESISTANCE



IMPACT RESISTANCE



AIR TIGHTNESS

HARDWARE SPECIFICATIONS

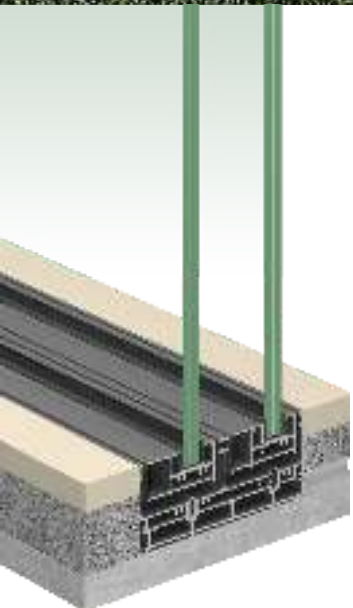

- Fix Rollers Up To 500 Kg Capacity.
- SS304 Wheel Roller with German Ball Bearing for Smooth Sliding in Heavy Shutter.
- Top & Bottom locking mechanism
- Customized Plastic Components Like handle adapter, frame joint adapter, shootbolt guide etc.
- Non Return Drainage Solution.
- All Size Of Glass Packers And Frame Packers.
- Microwave Cured EPDM Rubber Gasket For All Glass Size.
- All Hardware Is Having A 10 Years Of Operational Guarantee.

3 TRACK - 6 SHUTTER

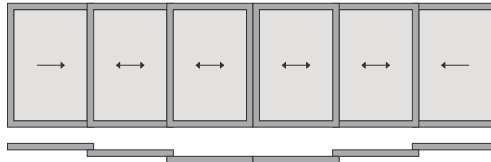

2 TRACK - 3 SHUTTER (X-2X-X)

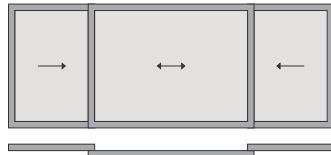

2 TRACK - 4 SHUTTER

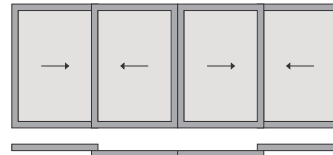

2 TRACK - 2 SHUTTER

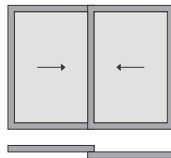

3 TRACK - 3 SHUTTER

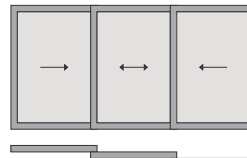

2 TRACK - 4 SHUTTER (CORNER OPENING)

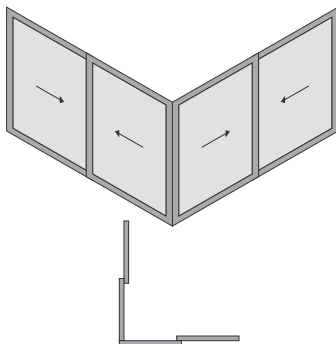

3 TRACK - 6 SHUTTER (CORNER OPENING)

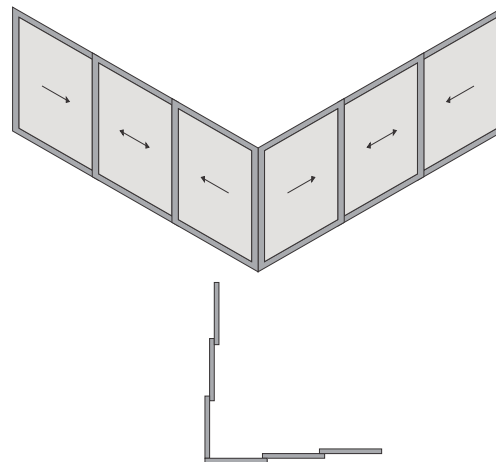

CS3000

CASEMENT SYSTEMS

This marvellously designed casement system is the ideal solution for bathroom vents, small windows and small fix partition which meets highest point of aesthetic performance & functionality. This casement series is having highest standard in terms of elegance, comfort, and performance.

Narrow sight line(76mm) with Inside and outside openable option, single point and multi point locking option & friction hinge and butt hinge option full fill all basic need of customer.

Proper euro groove of locking enhance the security perspective and heavy duty butt hinges enhance the performance perspective in this system also plastic accessories makes this system complete.

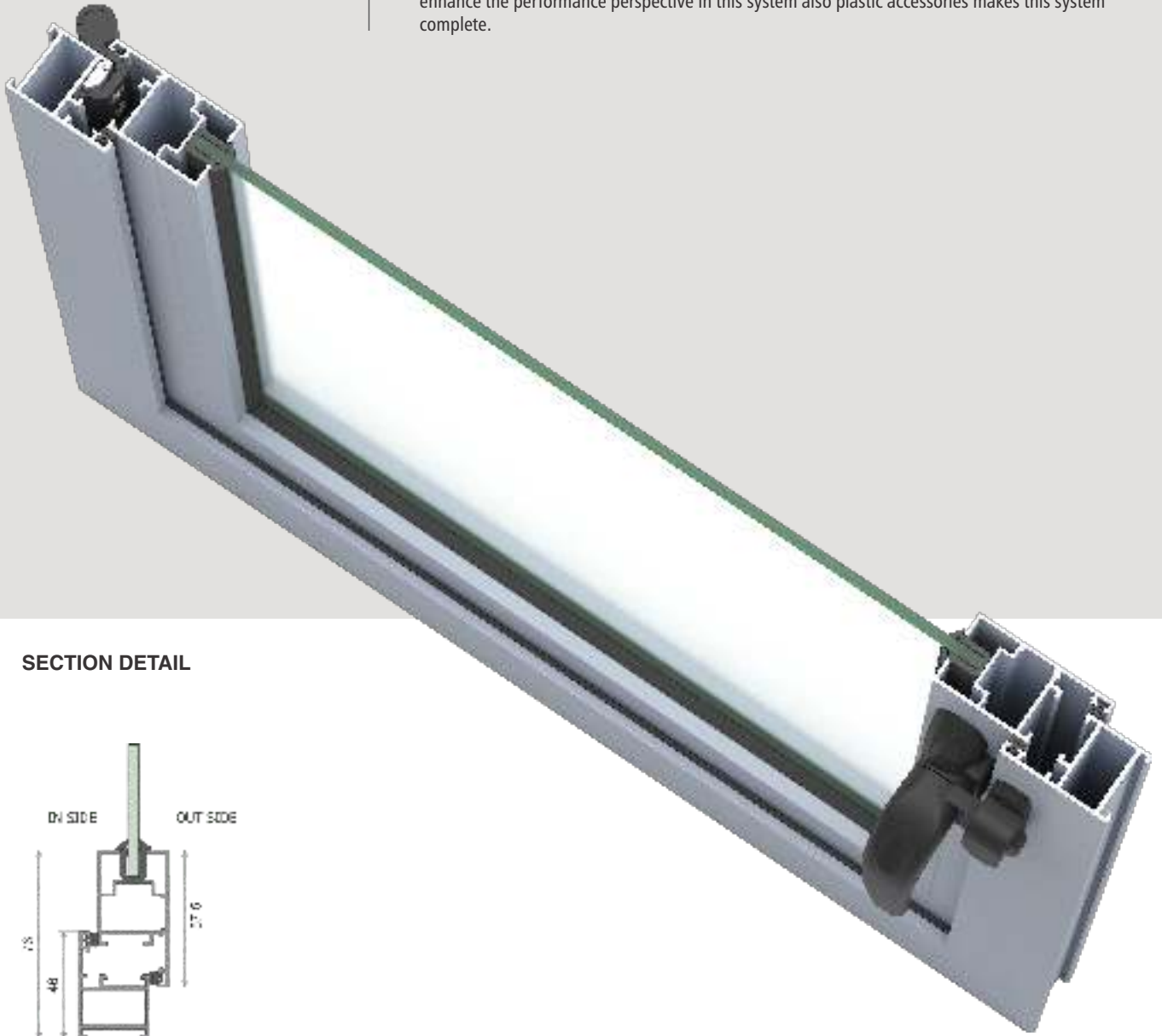

SECTION DETAIL

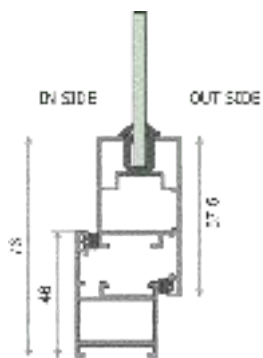



TECHNICAL SPECIFICATION

▶ Outer Frame Height	: 46mm
▶ Shutter Section Height	: 57.5mm
▶ Section Sightline	: 76mm
▶ Glass Thickness	: Upto 8mm
▶ Multi Point Locking	: Available
▶ Hinge Option	: Butt Hinge
▶ Friction Stay Option	: Available

WATER DRAINAGE



AIR
PERMEABILITY



SOUND
INSULATION



WATER
TIGHTNESS



WIND
RESISTANCE



IMPACT
RESISTANCE



AIR
TIGHTNESS

SYSTEM SPECIFICATION

- Flexible Design.
- 29mm Module.
- Especially For Bathroom Vents And Small Windows.
- Smooth & Effortless During Operation.
- Single Point And Multi Point Locking.
- Butt Hinge And Friction Hinge Option Available.
- Up To 8mm Glass Option Available.
- Inside And Outside Opening Possible.
- Corner Post For Shutter And Frame For Hairline Joint.
- Narrow Sightings (76mm) With Lateral Sill.
- Exceptional Sound Insulation By EPDM Rubber Gasket.
- Concealed Drainage On Frame.

HARDWARE SPECIFICATIONS



- Wide Range Of Locking Handles.
- Heavy duty hinges for good performance
- Single Point Lock.
- Euro Groove Multi Point Locking System
- friction hinges for small windows
- Restriction arm to restrict windows
- Non Return Drainage Solution
- All Size Of Glass Packers And Frame Packers
- Heavy Duty Adjustable Corner Cleat For Hair Line Joint
- Microwave Cured EPDM Rubber Gasket For All Glass Size
- All Hardware Is Having A 10 Years Of Operational Guarantee

SINGLE OPENABLE

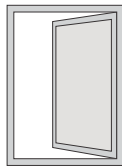

DOUBLE OPENABLE + MULLION

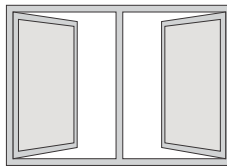

DOUBLE OPENABLE

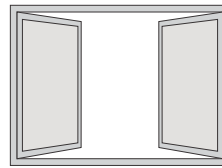

SINGLE OPENABLE + FIX

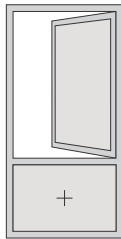

DOUBLE OPENABLE + MULLION + FIX

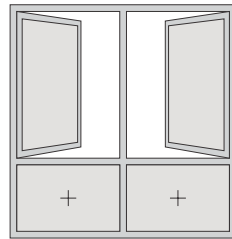

DOUBLE OPENABLE + FIX

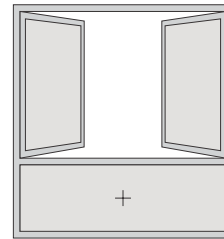

FIX + SINGLE OPENABLE

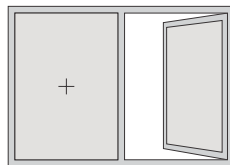

DOUBLE OPENABLE + CENTER FIX



FIX

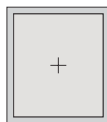

TOP HUNG

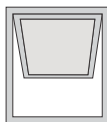

FIX+TOP HUNG

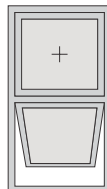

FIX+TOP HUNG+OPENABLE

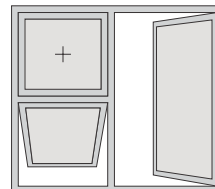

CS6000

CASEMENT SYSTEMS

This marvellously designed slim casement system is the ideal solution for lavish bungalows, villas & residential and commercial buildings which meets highest point of aesthetic performance & functionality. This slim casement series is having highest standard in terms of elegance, comfort, and performance.

Narrow sightline (80mm) with Inside and outside openable option, single point and multi point locking option & heavy duty fix hinge option full fills all basic need of customer.

Proper euro groove of locking enhance the security perspective and heavy duty fix hinges enhance the performance perspective in this system also plastic accessories makes this system complete.

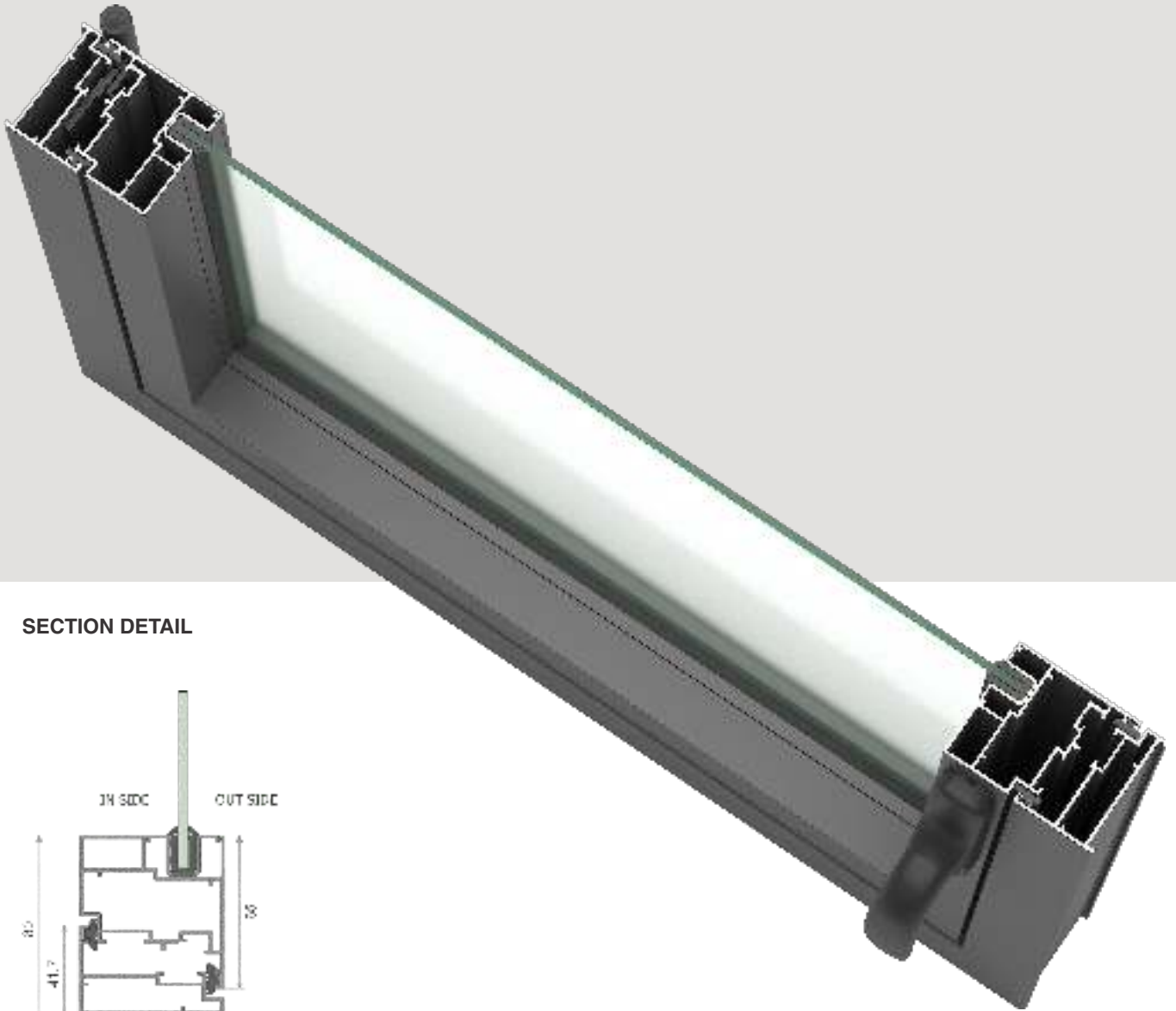

SECTION DETAIL

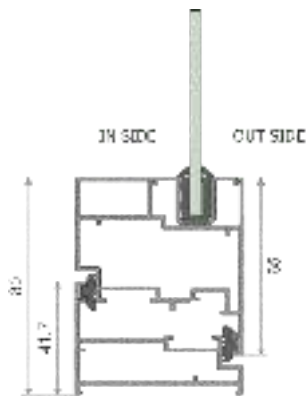



TECHNICAL SPECIFICATION

▶ Outer Frame Height	: 42mm
▶ Shutter Section Height	: 65mm
▶ Section Sightline	: 80mm
▶ Glass Thickness	: Upto 26mm
▶ Multi Point Locking	: Available
▶ Hinge Option	: Fix Hinge & Butt Hinge
▶ Friction Stay Option	: Available

WATER DRAINAGE



AIR PERMEABILITY



SOUND INSULATION



WATER TIGHTNESS



WIND RESISTANCE



IMPACT RESISTANCE



AIR TIGHTNESS

SYSTEM SPECIFICATION

- Minimalist Design.
- 60mm Module.
- Design for Bungalows & Project.
- Smooth & Effortless During Operation.
- Single Point And Multi Point Locking.
- Fix Hinge And Friction Hinge Option Available.
- Up To 26mm Glass Option Available.
- Inside And Outside Opening Possible.
- Corner Post For Shutter And Frame For Hairline Joint.
- Narrow Sightings (80mm) With Lateral Sill.
- Exceptional Sound Insulation By EPDM Rubber Gasket
- Concealed Drainage On Frame.
- Fly Mullion For Double Opening.

CS6000

CASEMENT SYSTEMS TILT & TURN

This marvellously designed slim casement system is the ideal solution for lavish bungalows, villas & residential and commercial buildings which meets highest point of aesthetic performance & functionality. This slim casement series is having highest standard in terms of elegance, comfort, and performance.

Narrow sightline (80mm) with Inside and outside openable option, single point and multi point locking option & heavy duty fix hinge option full fills all basic need of customer.

Proper euro groove of locking enhance the security perspective and heavy duty fix hinges enhance the performance perspective in this system also plastic accessories makes this system complete.

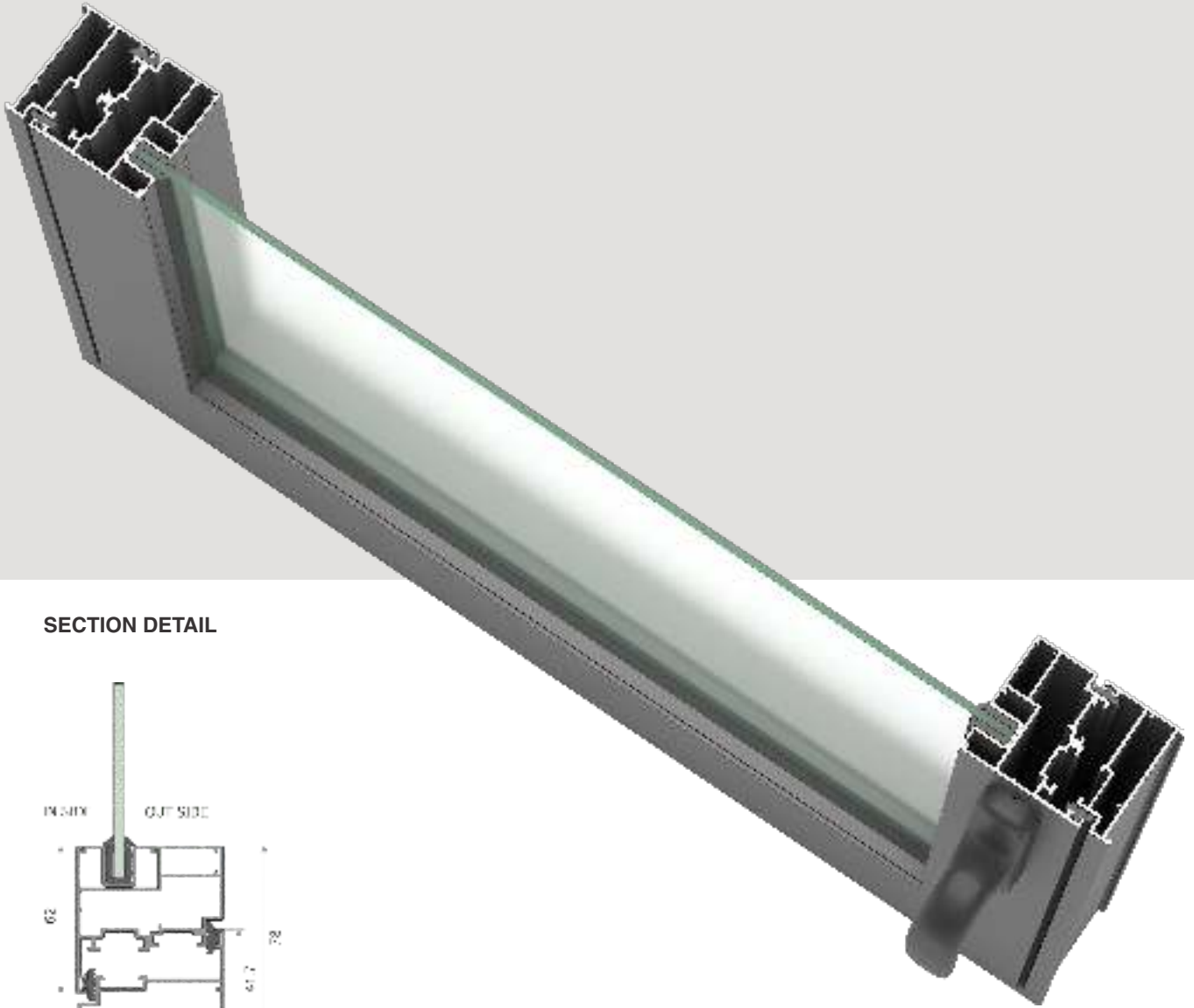

SECTION DETAIL

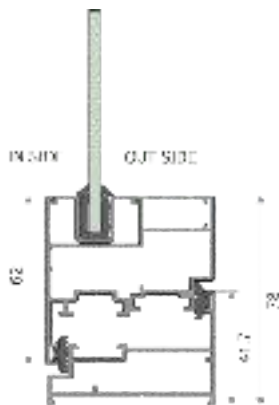

TECHNICAL SPECIFICATION

▶ Outer Frame Height	: 42mm
▶ Shutter Section Height	: 62mm
▶ Section Sightline	: 78mm
▶ Glass Thickness	: Upto 26mm
▶ Multi Point Locking	: Available
▶ Opening Degree	: 180°
▶ Friction Stay Option	: Available

LOCK POSITION



TILT POSITION



TURN POSITION



WATER DRAINAGE



AIR PERMEABILITY



SOUND INSULATION



WATER TIGHTNESS



WIND RESISTANCE



IMPACT RESISTANCE



AIR TIGHTNESS

SYSTEM SPECIFICATION

- Minimalist Design.
- 60mm Module.
- Design for Bungalows & Project.
- Smooth & Effortless During Operation.
- Multi Point Locking.
- Up To 26mm Glass Option Available.
- Corner Post For Shutter And Frame For Hairline Joint.
- Narrow Sightings (78mm) With Lateral Sill.
- Exceptional Sound Insulation By EPDM Rubber Gasket
- Concealed Drainage On Frame & Competition.
- Fly Mullion For Double Opening.



- Wide Range Of Locking Handles.
- heavy duty hinges for good performance
- Single Point Lock.
- Euro Groove Multi Point Locking System
- friction hinges for small windows
- Restriction arm to restrict windows
- Non Return Drainage Solution
- All Size Of Glass Packers And Frame Packers
- Heavy Duty Adjustable Corner Cleat For Hair Line Joint
- Microwave Cured EPDM Rubber Gasket For All Glass Size
- All Hardware Is Having A 10 Years Of Operational Guarantee

SINGLE OPENABLE

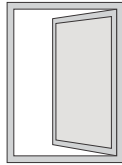

DOUBLE OPENABLE + MULLION

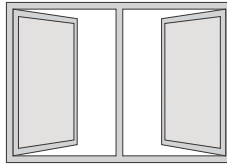

DOUBLE OPENABLE

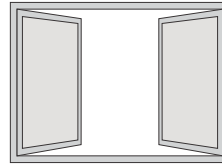

SINGLE OPENABLE + FIX

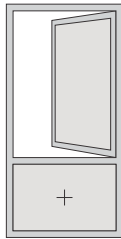

DOUBLE OPENABLE + MULLION + FIX

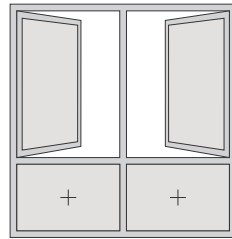

DOUBLE OPENABLE + FIX

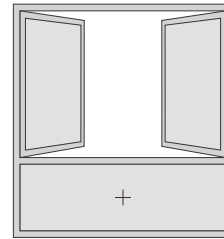

FIX + SINGLE OPENABLE

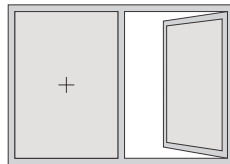

DOUBLE OPENABLE + CENTER FIX

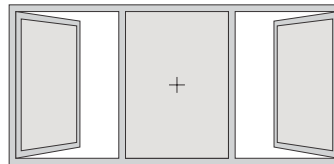

FIX

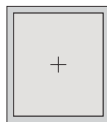

TOP HUNG

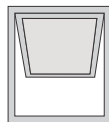

FIX+TOP HUNG

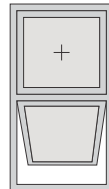

FIX+TOP HUNG+OPENABLE

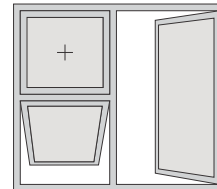

TILT & TURN TYPOLOGY

SINGLE OPENABLE
TILT & TURN

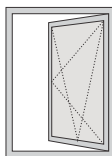

DOUBLE OPENABLE
TILT & TURN

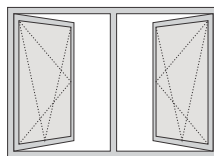

FIX + SINGLE OPENABLE
TILT & TURN

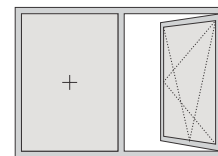

TILT & TURN
SINGLE OPENABLE + BOTTOM FIX

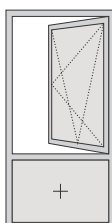

TILT & TURN
DOUBLE OPENABLE + BOTTOM FIX

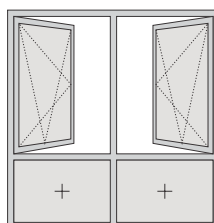

TILT & TURN
DOUBLE OPENABLE + CENTER FIX + BOTTOM FIX

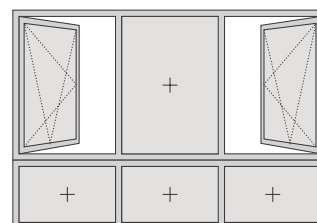

DS6000

DOOR SYSTEMS

This marvellously designed casement door system is the ideal solution for main entrance of lavish bungalows, villas, offices & residential and commercial buildings which meets highest point of aesthetic performance & functionality. This slim casement series is having highest standard in terms of elegance, comfort, and performance.

Narrow sightline (125mm) with Inside and outside openable option & heavy duty door hinge with adjustment facility option fullfills performance perspective.

Mortise with multipoint locking with Proper euro groove of locking enhance the security perspective for main entrance and plastic parts makes this system perfect.

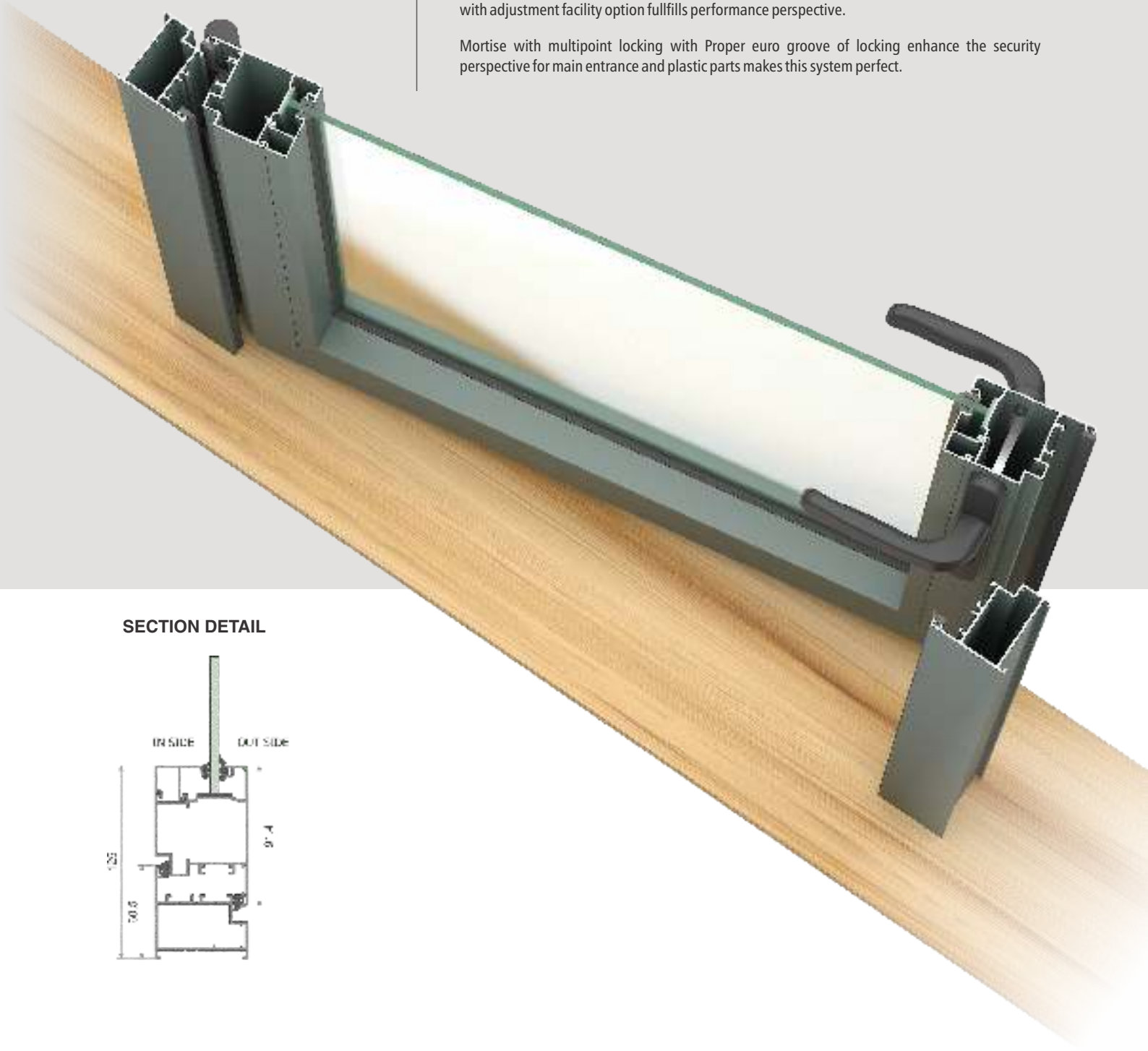

SECTION DETAIL

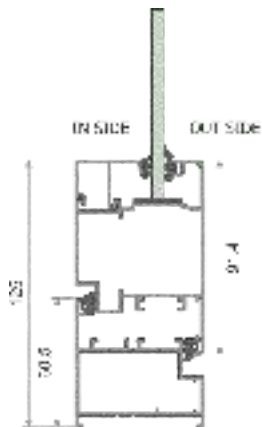

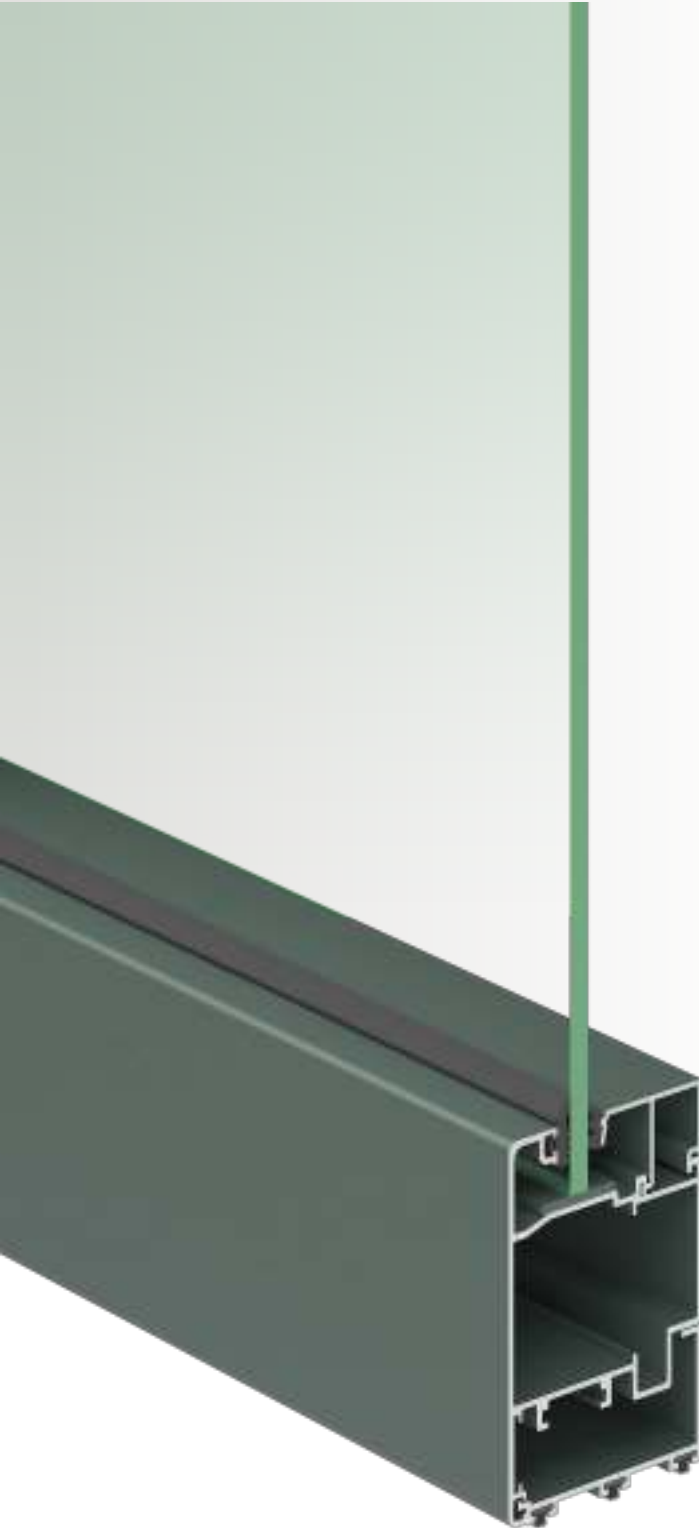

TECHNICAL SPECIFICATION

▶ Outer Frame Height	: 60.5mm
▶ Shutter Section Height	: 91.4mm
▶ Section Sightline	: 125mm
▶ Glass Thickness	: Upto 32mm
▶ Mortise Locking	: Available
▶ Mortise With Multi Locking	: Available
▶ Hinge Option	: Heavy Duty Door Hinges

WATER DRAINAGE



HI-TECH FEATURES



AUTOMATIC OPEN-CLOSE FUNCTION



TOUCH SCREEN



REMOTE CONTROL



VOICE CONTROL



AIR PERMEABILITY



SOUND INSULATION



WATER TIGHTNESS



WIND RESISTANCE



IMPACT RESISTANCE



AIR TIGHTNESS

SYSTEM SPECIFICATION

- Modern Design.
- 60mm Module.
- Design for Bungalows & Project.
- Smooth & Effortless During Operation.
- Multi Point, Mortise & Mortise With Multipoint Locking.
- Heavy Duty Door Hinge Available With Adjustable Facility
- Up To 32mm Glass Option Available.
- Inside And Outside Opening Possible.
- Corner Post For Shutter And Frame For Hairline Joint.
- Narrow Sightlines (125mm) With Lateral Sill.
- Exceptional Sound Insulation By EPDM Rubber Gasket.
- Concealed Drainage On Frame & Competition.
- Disabled Access Bottom Available.
- Fly Mullion For Double Opening.

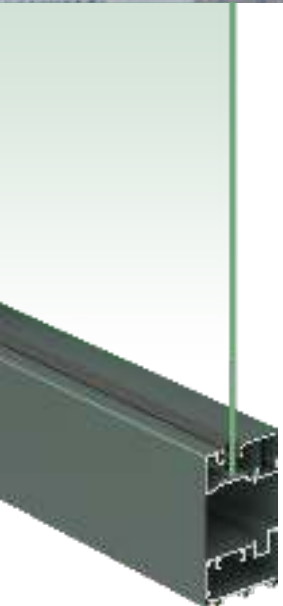

- Wide Range Of Mortise Handles.
- Heavy Duty Hinges For Good Performance
- Mortise With Multi Point Locking System
- Euro Groove Multi Point Locking System
- Mortise Single Point Locking System
- Non Return Drainage Solution
- All Size Of Glass Packers And Frame Packers
- Heavy Duty Adjustable Corner Cleat For Hair Line Joint
- Microwave Cured EPDM Rubber Gasket For All Glass Size
- All Hardware Is Having A 10 Years Of Operational Guarantee

SINGLE DOOR

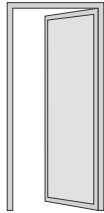

DOUBLE DOOR

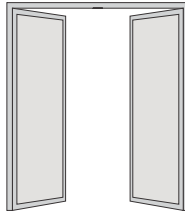

FIX + SINGLE DOOR

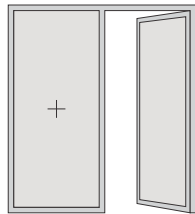

FIX + DOUBLE DOOR + FIX

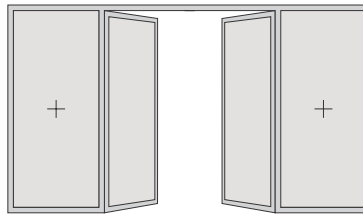

TOP FIX + SINGLE DOOR

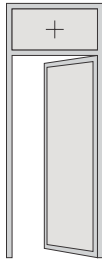

TOP FIX + DOUBLE DOOR

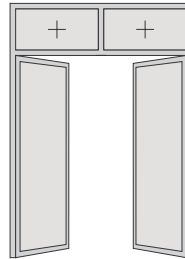

TOP FIX + SIDE FIX + SINGLE DOOR

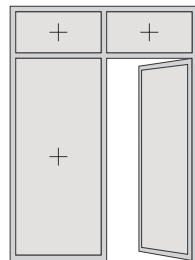

TOP FIX + SIDE FIX + DOUBLE DOOR

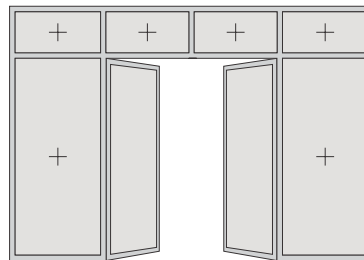

NOTES :

A series of horizontal dotted lines for taking notes.



WE OFFER WIDE **PRODUCT** RANGE

ALUKING®
— WHERE INNOVATION MEETS EXCELLENCE —

- ◆ SLIDING WINDOWS
- ◆ SLIDING DOORS
- ◆ MINIMAL SLIDING WINDOW
- ◆ CASEMENT SLIDING WINDOW
- ◆ CASEMENT SLIDING DOOR
- ◆ SLIDING & FOLDING SYSTEM
- ◆ TILT & TURN WINDOW
- ◆ AUTOMATIC OPENABLE WINDOW

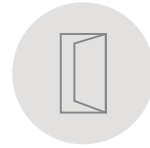
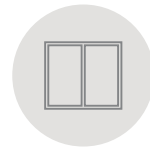

3DXDesignStudio

RARE WINDOW SYSTEM (INDIA)

Plot No. 397, GIDC Por, Vadodara - 391243, Gujarat, INDIA.
W : www.alukingsys.com



MAKE IN INDIA